

Digital Audio Tape Deck

Operating Instructions

DAT
Digital Audio Tape
DTC-87ES

© 1991 by Sony Corporation

WARNING

Operating Instructions

Before operating the unit, please read this manual thoroughly and retain it for future reference.

Owner's Record

The model number is located on the rear exterior and serial number is on the rear. Record the serial number in the space provided below. Refer to these numbers whenever you call upon your Sony dealer regarding this product.

Model No. DTC-87ES

Serial No.

WARNING

To prevent fire or shock hazard, do not expose the unit to rain or moisture.

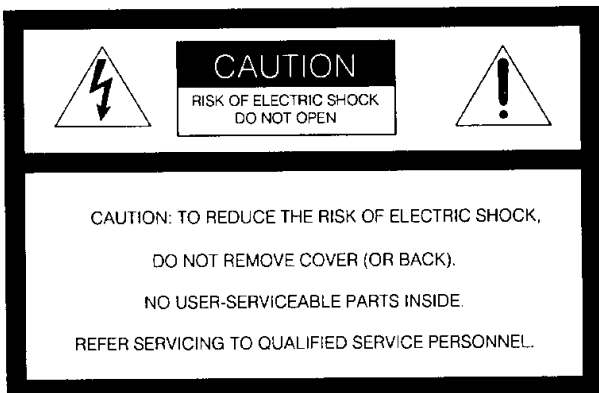

This symbol is intended to alert the user to the presence of uninsulated "dangerous voltage" within the product's enclosure that may be of sufficient magnitude to constitute a risk of electric shock to persons.



This symbol is intended to alert the user to the presence of important operating and maintenance (servicing) instructions in the literature accompanying the appliance.

INFORMATION (For the customers in the U.S.A.)

This equipment generates and uses radio frequency energy and if not installed and used properly, that is, in strict accordance with the manufacturer's instructions, may cause interference to radio and television reception. It has been type tested and found to comply with the limits for a Class B computing device in accordance with the specifications in Subpart J of Part 15 of FCC Rules, which are designed to provide reasonable protection against such interference in a residential installation. However, there is no guarantee that interference will not occur in a particular installation. If this equipment does cause interference to radio or television reception, which can be determined by turning the equipment off and on, the user is encouraged to try to correct the interference by one or more of the following measures:

Reorient the receiving antenna

Relocate the equipment with respect to the receiver

Move the equipment away from the receiver

Plug the equipment into a different outlet so that equipment and receiver are on different outlet so that equipment and receiver are on different branch circuits. If necessary, the user should consult the dealer or an experienced radio/television technician for additional suggestions. The user may find the following booklet prepared by the Federal Communications Commission helpful:

"How to identify and Resolve Radio-TV Interference Problems". This booklet is available from the U.S. Government Printing Office, Washington, DC 20402, Stock No. 004-000-00345-4.

For the customers in Canada

This apparatus complies with the Class B limits for radio noise emissions set out in Radio Interference Regulations.

For the customers in Canada

CAUTION: TO PREVENT ELECTRIC SHOCK, DO NOT USE THIS POLARIZED AC PLUG WITH AN EXTENSION CORD, RECEPTACLE OR OTHER OUTLET UNLESS THE BLADES CAN BE FULLY INSERTED TO PREVENT BLADE EXPOSURE.

Table of Contents

Before using the DAT deck

| | |
|---|----|
| Warning | 2 |
| Digital audio tape | 3 |
| Precautions | 4 |
| Feature | 5 |
| Location and function of controls | 6 |
| Front panel/remote commander | 6 |
| Remote commander operation | 9 |
| Installing batteries | 9 |
| Display window | 10 |
| Connections | 12 |
| Rear panel jacks | 12 |
| Connection examples | 13 |
| Time setting | 15 |
| Setting the date and time | 15 |
| Cassette loading | 17 |

Recording

| | |
|---|----|
| Before recording | 18 |
| Blank section and sound-muted portion | 18 |
| Absolute time codes | 18 |
| Recording | 19 |
| To record the recording date and time | 20 |
| To monitor the recording condition | 20 |
| To check the recording date and time | 20 |
| Creating a sound muted portion | 22 |
| End search | 22 |
| Fade-in/fade-out recording | 23 |
| CD synchronized recording | 23 |

Writing sub codes

| | |
|--|----|
| Sub codes | 24 |
| Start ID | 26 |
| Writing automatically during recording | 26 |
| Writing manually during recording | 27 |
| Writing manually during playback | 27 |
| Adjusting the position | 27 |
| Erasing | 27 |
| Program numbers | 28 |
| Writing automatically during recording | 28 |

| | |
|--------------------------------|----|
| Renumbering | 29 |
| Erasing | 29 |
| Skip ID | 30 |
| Writing during recording | 30 |
| Writing during playback | 30 |
| Erasing | 30 |
| End ID | 31 |
| Writing during recording | 31 |
| Writing during playback | 31 |
| Erasing | 32 |

Playback

| | |
|---|------------|
| Playback | 32 |
| Display window | 33 |
| Auto play: restarting playback after rewinding | 34 |
| Time search: fast-forwarding/rewinding the tape by designating the amount in minutes | 34 |
| Time search: To start playback by designating the elapsed time from the beginning of a tape | 34 |
| Various playback operations | 35 |
| Fade-in/fade-out play | 35 |
| Repeat play | 35 |
| Automatic music sensor operation | 37 |
| Music scan | 37 |
| Designating the desired selection | 38 |
| Skip play | 38 |
| Random music sensor operation | 39 |
| Timer activated operation | 40 |
| Timer activated recording | 40 |
| Timer activated playback | 40 |
| Maintenance | 41 |
| Cleaning the cabinet | 41 |
| Cleaning the head | 41 |
| Block diagram | 42 |
| Technical information | 43 |
| Recording format of DAT | 43 |
| Tape format and construction of DAT cassette | 43 |
| Track format | 44 |
| Troubleshooting | 45 |
| Specifications | Back cover |

Digital Audio Tape

DAT (Digital Audio Tape) is a new recording system which digitalizes the audio signal and records it on a DAT cassette tape.

DAT records the audio signal by converting the analog sound into a digital signal. This converting system is called the PCM (Pulse Code Modulation), and its accurate processing of the audio signal allows recording/playback with lower wow and flutter, wider dynamic range, lower distortion rate, and superb signal-to-noise ratio.

In addition, various control codes calls sub codes can be written on the DAT cassette separately from the audio signal. They are written for a variety of convenient playback/tape editing operations, and except for the absolute time, can be rewritten after audio signal recording has been completed.

Precautions

Safety

- Before operating the unit, be sure that the operating voltage of your unit is identical with that of your local power supply.
- The unit is not disconnected from the AC power source (mains) as long as it is connected to the wall outlet, even if the unit itself has been turned off.
- Should any solid object or liquid fall into the cabinet, unplug the unit and have it checked by qualified personnel before operating it any further.
- Unplug the unit from the wall outlet if it is not to be used for an extended period of time. To disconnect the cord, pull it out by grasping the plug. Never pull the cord itself.

Operation

Before making program source connections, be sure to unplug the unit.

Installation

- Do not install the unit in a location near heat sources such as radiators or air ducts, or in a place subject to direct sunlight, excessive dust, mechanical vibration or shock.
- Do not place anything on the top of the cabinet. The top ventilation holes must be unobstructed for the proper operation of the unit and to prolong the life of its components.

Moisture Condensation

If the unit is brought directly from a cold to a warm location, moisture may condense inside the unit. In this condition, the tape may adhere to the head drum and be damaged, or the unit may not operate correctly. Always remove the cassette when the unit will not be used.

If moisture is present...

- Function controls will not operate.
- All operations will stop.

When the CAUTION indicator lights and the unit will not operate

Leave the unit turned on for about an hour.

Detaching the Side Panels

After removing the screws, secure the cabinet with the supplied lock screws (M4 x 6). Do not use the longer screws.

For safety, before doing this, be sure to disconnect the AC power cord from the AC outlet.

NOTE

When closing the cassette compartment, do not push the cassette lid forcibly by hand, but perform with the OPEN/CLOSE button.

For the customers in the U.S.A.

For detailed safety precautions, see the "IMPORTANT SAFEGUARDS" leaflet.

If you have any question or problem connecting your unit, please consult your nearest Sony dealer.

Features

Serial copy management system

This unit utilizes the serial copy management system that permits digital-to-digital recording for one generation. You can record CD sound or other digital formats through a digital-to-digital connection.

4-Head, 4-DD Motor Mechanical Deck System

In addition to the standard two heads for recording and playback, this unit employs two additional heads for after-monitoring, forming a four-head system. This system allows after-monitoring of the recorded sound during recording in the same manner as with three-head cassette decks. In addition, the unit employs direct-drive motors for the drum, capstan, and reel drives, realizing silent and stable tape transport.

Date Function Automatically Records the Recording Date and Time

The year, month, day, day of the week, hour, minute and second are automatically recorded in the subcode area during recording, so that during playback you can display this data to check when the tape was recorded. This function is especially convenient when recording live performances, etc.

Three sampling frequencies

Recording/playback can be done with three sampling frequencies (48 kHz, 44.1 kHz and 32 kHz).
48 kHz: For analog and digital input signals in a standard mode.
44.1 kHz: For compact disc and pre-recorded DAT tape.
32 kHz: For analog input signals in a long-play mode.

Long Play mode

This unit can operate in a long-play mode. Analog input signals can be recorded or playback for up to four consecutive hours when the DT-120 DAT cassette tape is used. The sampling frequency will be 32 kHz in the long-play mode.

Visible cassette loading

You can view the tape operation through the lid of the cassette compartment.

Excellent sound quality

1-bit A/D converter

For the A/D converter section which converts analog input signals to digital signals, the unit employs a 1-bit A/D converter which theoretically generates no zero-cross distortion for a clear, elegant sound quality.

Pulse D/A converter

Superior playback performance is achieved through the combination of an 8X oversampling digital filter with a 1-bit D/A converter.

Independent Digital and Analog Power Sources

Since the design of the power source section is important for obtaining good sound quality, this unit incorporates two large-sized, large-capacity transformers for independently supplying power to the digital/mechanical deck sections and the analog section. This design eliminates from the source any interference introduced through the power supply.

Rich Variety of Subcode Information

This unit can record subcode information such as Start IDs, program numbers, Skip IDs, and absolute time data, enabling you to quickly locate tunes and display the playback time in the same manner as when playing compact discs.

High-Speed Search Function

Direct-drive reel motors and a software servo system enable you to locate tunes at high speeds up to 200-times the normal playback speed.

Digital fade-in/fade-out

Professional sounding fade-in/fade-out of either digital or analog signals can be accomplished by use of the FADER button.

Post edit recording of sub codes

You can record or rewrite the following sub codes after the audio signal recording has been completed.
Start ID: Signifies the beginning of a selection.
Program number: Gives a number to the selection.
Skip ID: Signifies the beginning of a portion to be skipped.
End ID: Signifies the end position of recording/playback.
Since sub codes are written on the tape separately from audio signals, the audio signals are not affected.

Location and Function of Controls

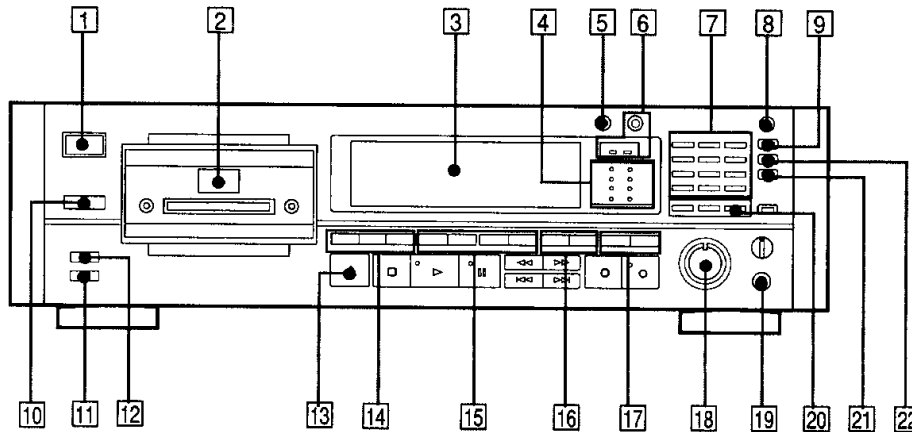

Front Panel/Remote Commander

- 1 POWER switch**
Turns the power on and off.
- 2 Cassette compartment**
Insert a cassette with the window side up and the safety tab facing you.
- 3 Display window**
- 4 ID indicators**
Display which ID button is pressed.
- 5 REC MODE selector**
Normally set to STANDARD.
When this selector is set to LONG, you can record analog input signals or digital signals with 32 kHz in the long-play mode.
- 6 REC MONITOR switch and indicators**
Switch the output signals from the LINE OUT jack, DIGITAL OUT jack and PHONES jack during recording.
In the SOURCE mode, the signal being input is output.
In the TAPE mode, the signal to be recorded is output.
- 7 Music select buttons**
Numeric buttons (0–9): Designate the desired program number to be played back before starting playback.
CLEAR: Use to cancel the program number which has been mistakenly entered.
MUSIC SCAN: Use this feature to listen to the beginning of each selection successively.
- 8 DISPLAY MODE button**
Change the display mode. (Refer to page 10.)
- 9 REPEAT button**
Press to play a desired portion repeatedly. Each time you press the button, the indication changes as follows:
REPEAT 1 → REPEAT ALL → Nothing
- 10 Remote sensor**
Receives the signal from the Remote Commander.
- 11 INPUT selector**
Set according to the signal to be recorded.
ANALOG: For recording from the equipment connected to the LINE IN jacks.
OPTICAL: For recording from the equipment connected to the DIGITAL IN (OPTICAL) jack.
COAXIAL: For recording from the equipment connected to the DIGITAL IN (COAXIAL) jack.
- 12 TIMER switch**
Normally set to OFF. Use start recording or playback at the desired time using a commercially available audio timer.
- 13 OPEN/CLOSE button**
Press when inserting or removing the cassette.

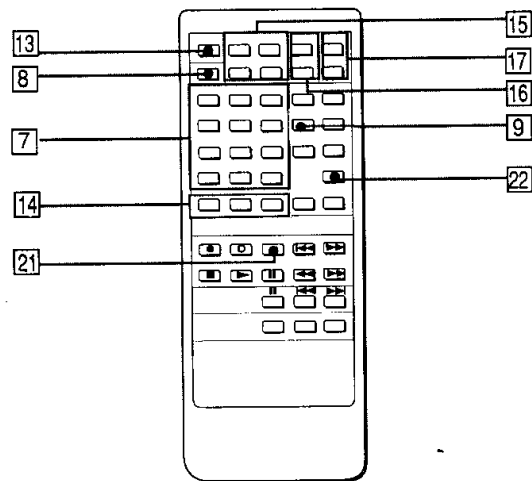

14 COUNTER buttons

MODE: Selects the counter display in the display window among the linear counter (tape running time), absolute time, elapsed time of the selection, and total remaining time of tape. Each time you press the button, the display changes sequentially.

RESET: Resets the linear counter to "0M 00S".

MEMORY: Press to search the position of the tape you want to listen to (Memory play, Memory stop).

15 START ID buttons

AUTO: Press to turn on and off the AUTO indicator. When the AUTO indicator is lit, the start ID will automatically be written during recording. When the AUTO indicator is not lit, press START ID WRITE at the point where you want to write a start ID.

WRITE: Press to write the start ID at the desired point during recording or playback.

ERASE: Press to erase a start ID. When a start ID and a program number are written on the tape, both codes are simultaneously erased by pressing this button.

RENUMBER: Press to renumber all programs on the tape. When only the start IDs are written, pressing this button will insert the proper program numbers beginning with "1". The tape will rewind and start from the beginning to accomplish this function.

16 SKIP ID buttons

WRITE: Press at the beginning of the portion you may wish to skip later. A skip ID will be written from the point where you pressed this button.

ERASE: Press to erase the nearest skip ID which is before the current position.

17 END ID buttons

WRITE: Press to write the ID signifying the end of playback or recording.

ERASE: Press to erase the end ID.

18 REC LEVEL (recording level) controls

Adjust the recording level for the analog input signals. The outer knob controls the L (left) channel level and the inner knob the R (right) channel level. The knobs can be adjusted together.

When recording digital signals, it is not necessary to adjust the recording level.

19 PHONES jack

20 CLOCK SET button

Press to adjust the time of the clock built in this unit. In this mode, The MUSIC SCAN button and the 0 button function as the + and - buttons respectively.

21 FADER button

Press to fade in or fade out during recording or playback.

22 SKIP PLAY button

Press to activate the skip ID code function. The portion of the tape previously marked will be skipped.

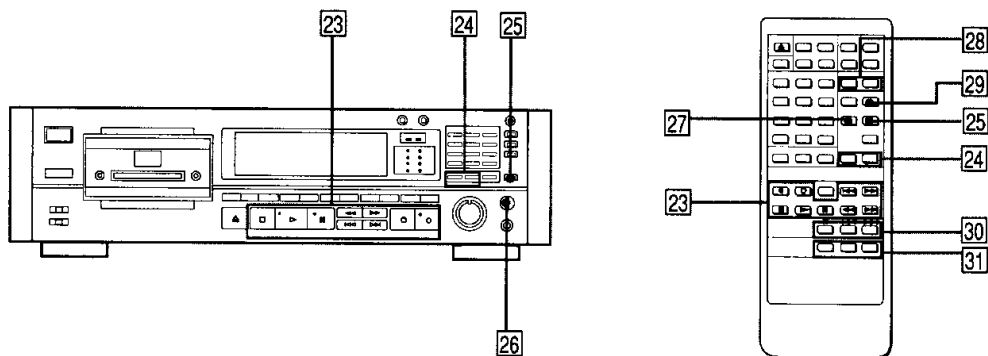

Front Panel/Remote Commander

23 Tape operating buttons

- (stop): Press to stop recording or playback.
- ▶ (play): Press to play back the tape.
- (recording): Press to start recording. After pressing this button, press ■ or ▶.
- ⏸ (pause): Press to stop for a moment during recording or playback. To restart recording or playback, press this button again or press ▶.
If the unit is left in the pause mode for about 10 minutes, it will automatically be released and the deck will enter the stop mode. To restart recording or playback from the stop mode, press REC or ▶ respectively.
- (record muting): Inserts a sound-muted portion (space).
- ⏮/▶ (AMS): Press to locate the beginning of the selection during the playback.
- ⏮/▶ (rewind/review, fast-forward/cue): In the stop mode, press to rewind/fast-forward the tape. During playback, press to rewind or fast-forward the tape while listening to the sound.

24 DATE button

- RECORDED:** Press to display the recording day of the tape being played.
- PRESENT:** Press to display the current time.
Each time the RECORDED or PRESENT buttons are pressed, year, month, and day display or hour, minute and second display is switched respectively.

25 MARGIN RESET button

Press to reset the margin of peak level.

26 PHONE LEVEL control

The PHONE LEVEL control adjusts the headphones volume level.

27 TIME SEARCH button

Press to search the position of the tape you want to listen to by giving the time elapsed from the beginning of the tape.

28 RMS play buttons

ENTER: To program the selections in a desired order, press this button after pressing the numeric buttons.
CHECK: Press to check the programmed contents.

29 REPEAT A ↔ B button

Press to play back a desired portion repeatedly.

30 CD operation buttons

Operative only for the Sony CD player equipped with a Remote Commander.

⏸ (pause): Sets the CD player in the pause mode during playback. Press again to release pause. If pressed twice when the player is in the stop mode, playback starts.

⏮/▶ (AMS): Press to locate the desired selection on the Compact Disc during playback or in the stop mode.

31 CD SYNCHRO (CD synchronized recording) buttons

(The playback of the CD player equipped with a Remote Commander and the recording of the DAT deck can be performed simultaneously.)

STANDBY: Press to set the unit in the record-standby mode.

START: Press to start recording of the DAT deck and then playback of the CD player.

STOP: Press to stop the DAT deck recording and the CD player playback.

Remote Commander Operation

Each button on the Remote Commander functions in the same way as those having the same name on the front panel.

However, the following operations cannot be performed using the Remote Commander. Use the front panel controls instead.

- Turing the power on and off
- Selecting digital(optical/coaxial)/analog input source
- Adjust the recording level headphones level
- Setting the timer recording/playback
- Selecting the record mode (standard or long)
- Setting the REC MONITOR switch.

The following operations can be performed only with the Remote Commander.

- Activating CD synchronized recording using a Sony CD player and controlling the CD player
- Locating the desired selection on the Compact Disc setting the CD player in the pause mode (possible o when a Sony CD player is used.)
- Repeat play (A-B)
- RMS* play
*RMS: Random Music Sensor
- Time search (When locating the desired position of the tape by giving the time elapsed from the beginning of the tape.

Installing Batteries

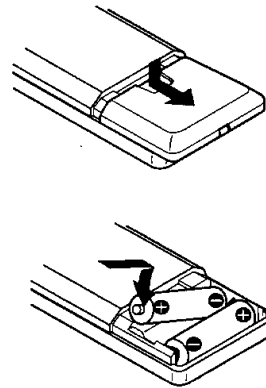

Insert two size AA (R6) batteries with correct polarity, and close the lid.

Notes on remote control

- Do not expose the remote sensor on the deck to strong light such as direct sunlight, lighting apparatus, etc.
- Do not place any obstructions between the Remote Commander and the remote sensor, or else operations will not be performed correctly.
- The controllable range is limited. Point the Remote Commander directly at the remote sensor on the deck.
- When remote control operation distance becomes shorter, the batteries are weak. Replace both batteries with new ones.

To avoid battery leakage

When the commander will not be used for a long period of time, remove the batteries to avoid damage caused by battery leakage and corrosion.

Battery life

About half a year of normal operation can be expected when using the Sony SUM-3 (NS) batteries.

Display Window

To turn off the display window

When the power is turned on, the display window also is turned on. During recording or playback, all display or some parts of the display can be turned off. Each time the DISPLAY MODE button is pressed, the indicators changes as follows:

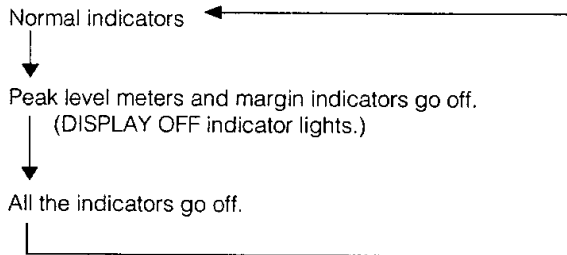

To change the brightness of the display window

While pressing COUNTER MODE, press one of the numeric buttons 1, 2 and 3. The greater number pressed, the darker the display window becomes. (When operating with the Remote Commander, also press COUNTER MODE.)

1 LONG PLAY mode indicator

Lights when recording or playback is being performed in the long play mode.

2 DATE indicator

Lights when pressing the RECORDED to display the recording day of the tape being played. Lights off when pressing PRESENT button to display the current time.

3 EMPHASIS indicator

Lights when a tape recorded with emphasis is played back, or when recording from a digital signal on which emphasis is applied. The emphasis function reduces the noise of the high frequency level by boosting the high frequency level during recording (Pre-emphasis function) and by lowering it during playback (De-emphasis function). This unit incorporates only the de-emphasis circuit. You can play or record the emphasized signal but newly applying emphasis cannot be performed.

4 COPY PROHIBIT indicator

Lights when recording the digital signal with the copy prohibit code. In this case, record with the LINE IN jack.

5 TOC (Table of contents) indicator

When a pre-recorded DAT cassette is played back, this indicator will light.

6 SKIP PLAY indicator

When this indicator is lit during playback, the portion marked by the skip ID is skipped and playback continues from the next start ID.

7 SAMPLING FREQ. (Sampling frequency) indicator

- 48 kHz:** For recording/playback of analog input signals (standard mode)
- 44.1 kHz:** For recording/playback of CD and a prerecorded DAT cassette
- 32 kHz:** For recording/playback of analog input signals (long-play mode)

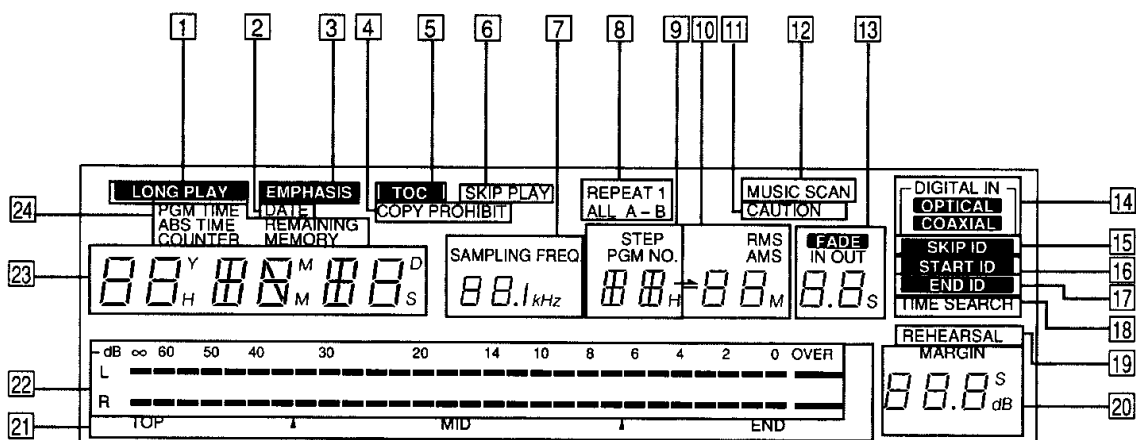

8 REPEAT indicators

REPEAT 1: Lights when a desired selection is played back repeatedly.

REPEAT ALL: Lights when all the selections are played back repeatedly.

REPEAT A-B: Lights when a desired portion is played back repeatedly.

9 STEP/PGM NO. indicator

Shows the program number of the selection being played. When programming the desired selection in the RMS operation (page 39), the display shows the step number of the programmed selection.

10 AMS (Automatic Music Sensor)/RMS (Random Music Sensor) indicators

Show the number of selections to be skipped ahead or behind in the AMS operation. When designating a selection directly by the numeric button and the ► button, the display shows the program number of the target selection while the selection is being searched for. When programming the desired selections in the RMS operation (page 39), the display shows the program number of the selection to be programmed.

11 CAUTION indicator

Lights when moisture condensation occurs. If this happens, the deck stops functioning automatically. (See page 4.)

12 MUSIC SCAN indicator

Lights after pressing the MUSIC SCAN button to listen to the beginning of each selection successively.

13 FADE IN/OUT indicator

FADE IN: Blinks when recording or playback fades in.

FADE OUT: Blinks when recording or playback fades out.

14 Indicator of the input selector

The OPTICAL or COAXIAL indicator lights according to the position of the INPUT selector. No indicator lights when the INPUT selector is set to ANALOG.

15 SKIP ID indicator

Lights when writing or erasing a skip ID code or when the skip ID is detected during playback.

16 START ID indicator

Blinks when writing (for 9 or 18 seconds) or erasing a start ID code, and lights when the start ID is detected during playback.

17 END ID indicator

Blinks when writing (for 9 or 18 seconds) or erasing an end ID code, and lights when the end ID is detected during playback.

18 TIME SEARCH indicator

Lights when searching the desired position of a tape by giving the time elapsed from the beginning of the tape.

19 REHEARSAL indicator

Lights while the rehearsal function is activated (page 27).

20 MARGIN indicator

Shows how much margin there is between the peak level of input audio signal and 0 dB.

21 Frequency map indicator

Bars indicating the sampling frequencies with which the tape was recorded appear on the peak level meters. (Refer to page 33.)

22 Peak level meters

Indicate the peak value of the audio signal being recorded when the REC MONITOR switch is set to SOURCE or the peak value of the audio signal recorded on the tape when the REC MONITOR switch is set to TAPE.

23 Time indicator

Indicates the tape running time, absolute time, elapsed time of the current selection, remaining time or recording day. Each time the COUNTER TIME button is pressed, the display is changed.

24 REMAINING (remaining time): Lights when the counter shows the remaining time of the tape.

PGM TIME (program time): Lights when the counter shows the elapsed time of the current selection.

ABS TIME (absolute time) indicator: Lights when the counter shows the elapsed time from the beginning of the tape.

COUNTER indicator: Lights when the counter shows the tape running time.

MEMORY indicator: Lights when the MEMORY function can be performed in the COUNTER mode.

Connections

Rear Panel Jacks

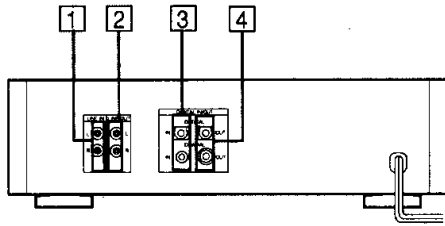

1 LINE IN (line input) jacks (phone jack)

Connect to the recording outputs of an amplifier. Signals supplied by the amplifier can be recorded using the sampling frequency of 48 kHz in the normal play mode or 32 kHz in the long play mode.

2 LINE OUT (line output) jacks (phono jack)

Connect to the DAT or tape inputs of an amplifier. The playback signal of this deck will be output.

3 COAXIAL/OPTICAL DIGITAL IN (digital input) jacks (coaxial phono jack/optical jack)

Connect to the digital outputs of an amplifier having a built-in D/A converter or other digital source, such as a CD player for digital-to-digital recording.

4 COAXIAL/OPTICAL DIGITAL OUT (digital output) jack (coaxial phono jack/optical jack)

Connect to the digital inputs of an amplifier having a built-in D/A converter or another DAT deck, for playback of a DAT cassette or digital-to-digital recording.

Notes on connection

- Use the connecting cords specified in the illustrations.
- Turn off the power for all equipments before making connections.
- Be sure to insert the plugs firmly into the jacks. Loose connections may cause hum and noise. When unplugging, grasp the plug and not the cord.

Notes on the optical cable

- Do not bend the cord. When the cord is not used, curl it with a diameter of more than 15 cm (5 7/8 inches).
- Do not use it under high temperatures.
- When the optical cable is not connected, cover the OPTICAL IN/OUT jacks with the supplied caps.

Note on sound signals

When connecting an optical cable to the DIGITAL IN/ DIGITAL OUT jacks, sound signals (L/R) are transmitted together through the cable.

Connecting Cord

There are following three types of connecting jacks at the rear of the deck. Each type of jack requires a different type of connecting cord.

| | |
|--|--|
| <p>LINE IN/OUT (analog input/output) jacks</p> | <p>Audio signal connecting cord (supplied, or optional RK-C505KS etc.)</p> |
| <p>COAXIAL IN/OUT (digital input/output) jacks</p> | <p>Coaxial digital connecting cord (optional VMC-1ES etc.)</p> |
| <p>OPTICAL IN/OUT (optical transmission digital input/output) jacks</p> | <p>Optical cable (optional POC-15 etc.)</p> |

Connection Examples

If your amplifier is not equipped with digital signal jacks

— : Analog signal connecting cords
 = : Digital signal connecting cords
 (coaxial cord or optical cable)
 ⇐ : Signal flow

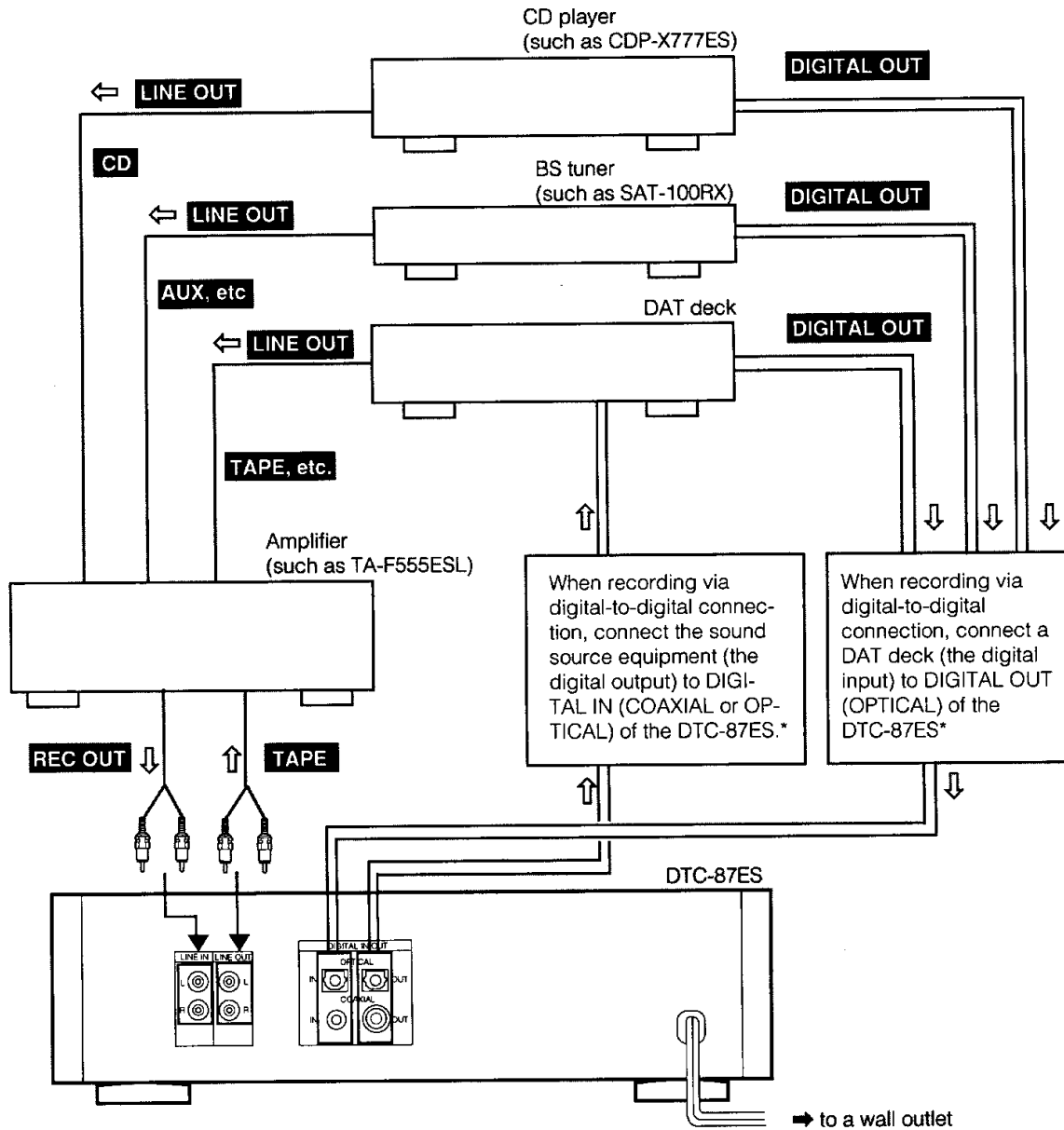

When connecting a microphone

Connecting a stereo microphone amplifier (the analog output) to LINE IN of the DTC-87ES.

*If "COPY PROHIBIT" appears in the display window, recording via digital-to-digital connection cannot be performed. In this case, connect the sound source equipment using LINE IN and OUT jacks.

Connection Examples

If your amplifier is equipped with digital signal jacks

- : Analog signal connecting cords
- ≡ : Digital signal connecting cords (coaxial cord or optical cable)
- ⇨ : Signal flow

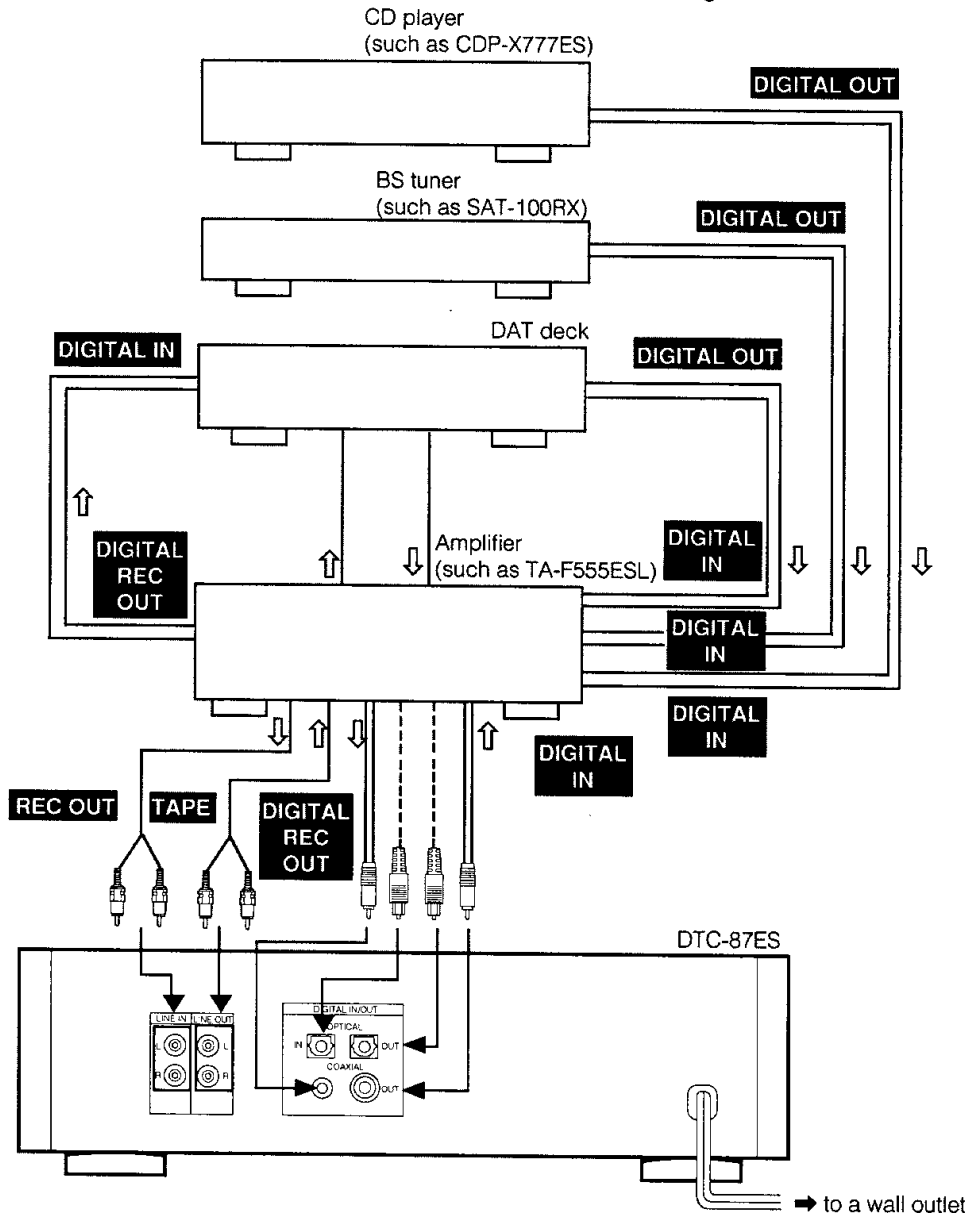

*If "COPY PROHIBIT" appears in the display window, recording via digital-to-digital connection cannot be performed. In this case, connect the sound source equipment using LINE IN and OUT jacks.

Time Setting

This unit employs a built-in clock to keep track of the current date and time. Once you set the date and time, this information will be recorded on the tape along with the audio signal during recording. This function is very convenient because it allows you to check when the tape was recorded when playing the tape later.

Setting the date and time

Example: Setting the clock to 10:30:00 AM, July 4, 1991 (Thursday)

Setting the date

1 Display the current date.

PRESENT

2 Set the year.

CLOCK SET

0 (-) MUSIC SCAN (+)

3 Set the month.

CLOCK SET

0 (-) MUSIC SCAN (+)

4 Set the day.

CLOCK SET

0 (-) MUSIC SCAN (+)

5 Set the day of the week.

CLOCK SET

0 (-) MUSIC SCAN (+)

6 Complete the setting procedure.

CLOCK SET

Time Setting

Setting the time

1 Display the current time.

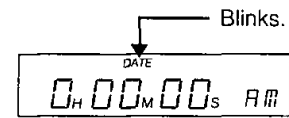

2 Set the hour.

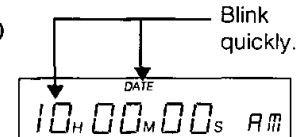
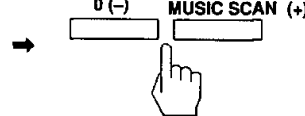
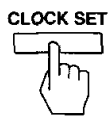

3 Set the minutes.

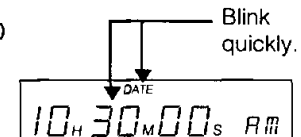
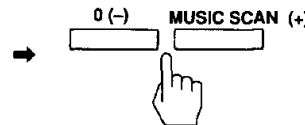
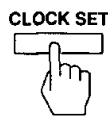

4 Set the seconds to 0.

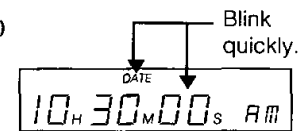
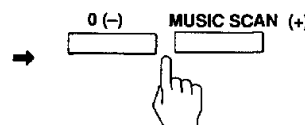
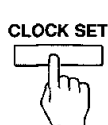

5 Start the clock simultaneously with the signal from a timecast (telephone, etc.).

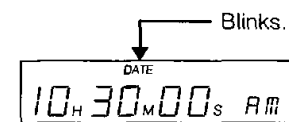
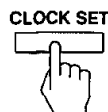

To confirm the date or time

Press the PRESENT button to display the date or time. One press displays the date and two presses displays the time. To return to the original counter display, press the COUNTER button.

Time display

The time is displayed in 12-hour format. Midnight and noon are displayed as follows:
Midnight: AM 12:00
Noon: PM 12:00

Built-in clock

This unit's built-in clock operates using a quartz oscillator, and time variations caused by changes in temperature, etc., may accumulate. For precise recording of hour, minute, and second data by the built-in date function, it is recommended that you set the clock once a week.

Precautions when setting the time

- Set the time while the tape is stopped.
- Although this unit's clock automatically adjusts for leap years and long and short months, do not enter a date which does not exist.

A The day of the week and AM/PM are displayed as follows.

| | |
|-----------|----|
| Sunday | SU |
| Monday | MO |
| Tuesday | TU |
| Wednesday | WE |
| Thursday | TH |
| Friday | FR |
| Saturday | SA |

| | |
|----|----|
| AM | AM |
| PM | PM |

Note

This unit uses a back-up battery to keep the clock running when the power is turned off. The life of the battery under normal use is approximately five years. When the battery starts to run down, the clock will stop operating normally. When this occurs, have the battery replaced at your dealer or nearest Sony Service Center (a battery replacement fee is required).

Cassette Loading

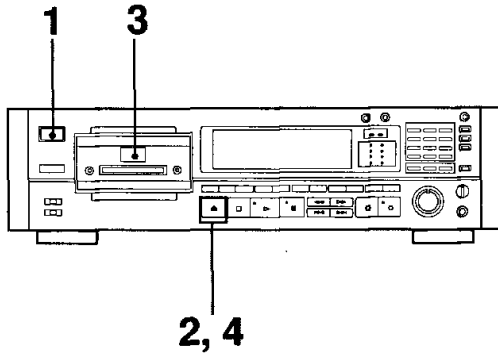

1 Turn on the power.

2 Press OPEN/CLOSE.

3 Insert the cassette.

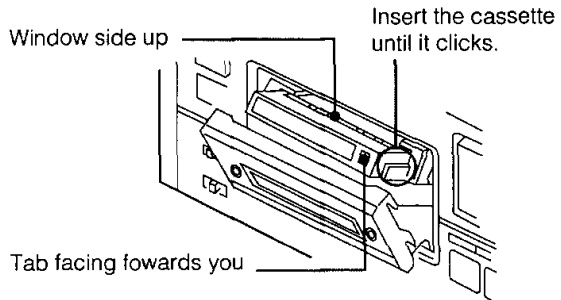

4 Press OPEN/CLOSE.

The lamp in the cassette compartment lights.

To remove the cassette

Press OPEN/CLOSE.

On a digital audio tape

Only the digital audio tape made especially for DAT deck is required.

Unlike an ordinary cassette tape, a digital audio tape can be used only one side.

- Digital audio tape is designed to avoid a dust. Do not open the inside of the tape.
- The hole at the back of a tape is a detector slot. Do not cover the slot.

To prevent accidental erasure

When a recording is made, any previously recorded signal will be erased automatically. To prevent accidental erasure, set the safety tab to the position shown in the illustration.

With the hole open, rewriting sub codes cannot be performed.

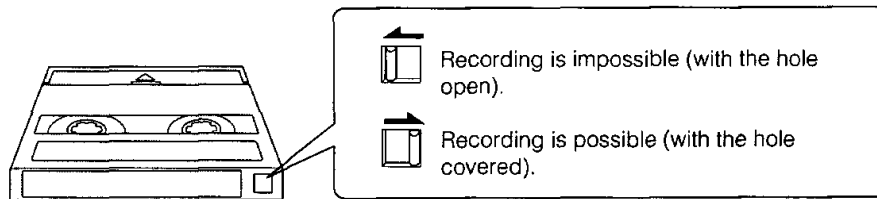

Notes

- When you turn on the power, the **II** indicator blinks for a moment in the display window. During this period, no buttons other than OPEN/CLOSE and **▶** are operative. Wait until blinking stops and **II** goes off.
- When inserting the cassette, do not push the cassette compartment closed. Be sure to use the OPEN/CLOSE button.

On the sampling frequency

When a cassette is inserted and a source program is play back, the sampling frequency of the source program appears in the display window.

Before Recording

Blank Section and Sound Muted Portion

With conventional analog audio tapes, the tape portion on which no recording ever has been made and the portion on which a recording has been made but the sound is muted are treated the same, since no sound can be heard from these portions.

However, with DAT cassette, you should know that the two kinds of "no sound" portions must definitely be distinguished one from the other.

Blank section

Means the portion on which no recording ever has been applied.

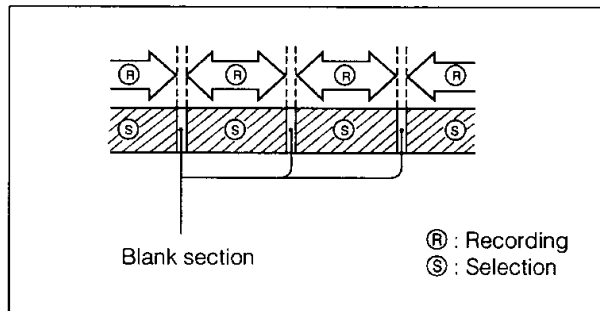

Sound portion

Means the portion on which a recording has been applied but that no audible sound is recorded.

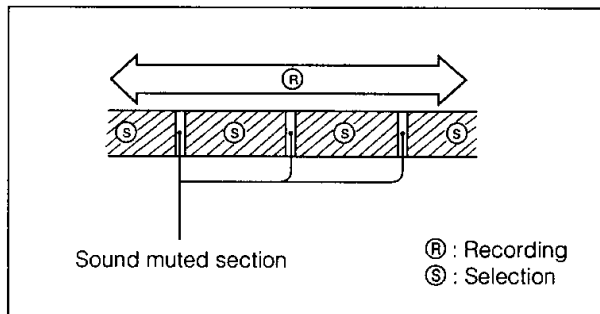

Important

When recording, be certain that not blank section is left on the tape. If blank sections remain on the tape, search operations using the AMS buttons, for example, may take quite a long time.

Difference between the blank section and sound-muted portion

When you record, a track format is constructed on the recorded area, even if the sound is muted during recording. On the blank section, since no recording is applied, there is no track format. See page 44 for details on the track format.

Absolute Time Codes

The absolute time codes correctly recorded on the tape can be used in various convenient ways during playback.

Recording absolute time codes

When you record, the absolute time codes are also recorded automatically from the beginning of the tape. Note, however, that the absolute time codes are not recorded if you start recording from the middle of blank section. No blank sections should be left on the tape when recording.

Tips for recording:

- To insert silence between selections, use the record muting function (page 22). Do not advance the tape with ►► or ►.
- To start recording from the middle of the tape, use the end search function (page 22) to locate the beginning of the blank section. This will avoid leaving a blank section.
- When loading the tape recorded the absolute time codes, the ABS TIME indicator is displayed, otherwise, the COUNTER indicator is displayed.

If a blank section is left on the tape

If you start recording from the middle of a blank section, the absolute time codes are not recorded, since the DAT deck can no longer count the absolute time from the beginning of the tape.

Recording

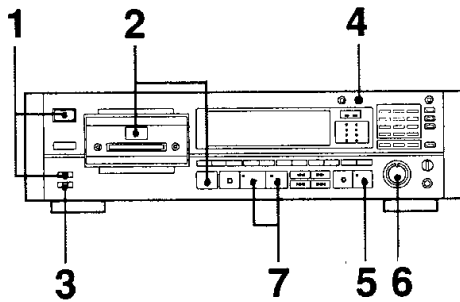

- 1 Make sure the TIMER is set to OFF, and turn on the power.**

- 2 Insert a cassette and press \blacktriangle to load the cassette. (See page 17.)**
Then locate the position at which you want to start recording.
To start recording from the beginning of the tape, press \blacktriangleleft . (The TOP indicator will appear at the beginning of the tape.)
To start from the middle of the tape, locate the point immediately before the blank section. (See page 22).
If recording has been applied to the entire tape and there is no blank section, locate the desired point by playing back.

- 3 Set the INPUT selector to ANALOG, OPTICAL or COAXIAL depending upon your sound source.**

- 4 Set the REC MONITOR switch to SOURCE.**

- 5 Press REC.**
●, \blacktriangleright and II indicators light, and the deck enters the record-pause mode. The sampling frequency to be applied for recording appears.
If the digital copy prohibit signal is written on the codes of the sound source, the COPY PROHIBIT indicator appears in the display window and signifies that you cannot record that source with the digital-to-digital connection. In this case, use the analog-to-analog connection.

- 6 When recording the analog input signal, adjust the recording level. (See page 21.)**
No recording level adjustment is required when recording the digital input signal.
Only the analog input signal and the digital signal of 32 kHz (Satellite broadcast A mode) can be recorded in the long-play mode.

- 7 Press PAUSE or \blacktriangleright (play).**
The II indicator goes off, and recording starts.

To record in the long-play mode
Set REC MODE to LONG. (See page 21.)

To write start ID automatically during recording
Make sure that the AUTO indicator is lit.
If not, press START ID AUTO. (See page 26.)

To designate the program number
Press the desired numeric button. (See page 28.)
When recording from the beginning of the tape, the program number will be assigned automatically from 1.

To insert sound muted portion at the beginning of the tape
Do not advance the tape with \blacktriangleright or \blacktriangleright . This will leave a blank section at the beginning. Be sure to proceed with the record muting function. (See page 22.)

To stop recording

Press \blacksquare .

To stop recording for a moment

Press II .

To release pause and restart recording

Press II or \blacktriangleright .

To remove the cassette

Press \blacktriangle .

- When you press FADER or REC MUTE, the deck will also enter the record-pause mode.

If recording cannot be made

Check the following:

- The safety tab of the cassette is set to the record-inhibit position. (See page 17.)
- No cassette is loaded.
- The INPUT selector is set to the incorrect position.
- Tape is fully rewound to the end.
- The output level of the playback equipment is too low.
- The digital copy prohibit signal is written in the codes of the sound source you want to record. (The COPY PROHIBIT indicator appears in the display window.)
- The REC LEVEL control is set to the 0 position. (Only when recording the analog input signal.)

Note on the INPUT selector and the REC MODE selector

Do not change the position of these selectors after recording starts.

If the cassette is ejected after it has been loaded

Check to see if the cassette is inserted correctly. (See page 17.)

When the tape is recorded to the end (Auto rewind function)

The tape is rewound to the beginning and stops automatically.

The auto rewind function is not applied when the TIMER switch is set to the REC position.

To record the recording date and time

Once the built-in clock is set, the date and time of recording will automatically be recorded on the tape along with the audio signal. When playing the tape back later, you can display this information to check when the tape was recorded.

To check the date and time being recorded, press the PRESENT button to display the current date and time.

Note

If you use another DAT deck to record subcodes (using the renumbering function, etc.) on a tape initially recorded on this unit, the recording date and time data may be erased from those sections of the tape.

To monitor the recording condition

In addition to the usual recording/playback heads, this unit is also equipped with heads for after-monitoring. This allows you to monitor the recorded sound immediately after it has been recorded on the tape, and enables you to switch between the source sound and the recorded sound during recording to check the actual effect of level settings and sound quality adjustments with your own ears. You can hear the source sound by setting the REC MONITOR switch to SOURCE, and you can monitor the recorded sound by setting the switch to TAPE. During playback, the tape sound is selected automatically regardless of the switch position. If your amplifier has a monitor switch, set it to the TAPE position.

REC MONITOR switch output signal

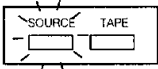
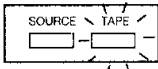
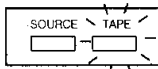
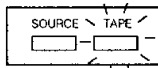
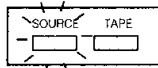
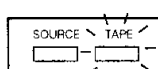
| | The position of the REC MONITOR switch | The indicator of the REC MONITOR switch | Output signal |
|------------------|--|---|---|
| During recording | SOURCE |  | The input source sound is heard. |
| | TAPE |  | The simultaneously monitored tape sound is heard. The tape sound is heard. |
| During playback | SOURCE |  | When the tape is stopped, the input source sound is heard. The tape sound is heard. |
| | TAPE |  | When the tape is stopped, no sound is heard. |
| During stop mode | SOURCE |  | The input source sound is heard. |
| | TAPE |  | No sound is heard. |

Also, since the deck reads the subcodes recorded on the tape when a DAT cassette is loaded or when a tape is fast-forwarded or rewound, the TAPE indicator lights and no sound is heard during these operations.

To check the recording date and time

During playback you can check the recording date and time which was recorded on the tape at the same time the audio signal was recorded. (No display will appear if the recording date and time are not recorded on the tape.)

To display the recorded date and time, press the RECORDED button. Each press of the button changes the display according to the following sequence.

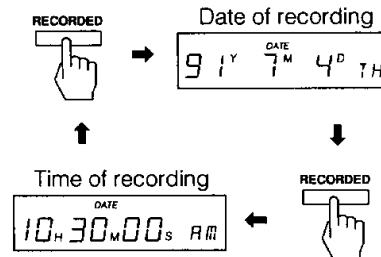

To check the current date and time

Press the PRESENT button. The date and time are displayed in the same way as with the RECORDED button.

When the EMPHASIS indicator appears.

When recording the digital signal with emphasis, the tape to be recorded is also applied emphasis. (The EMPHASIS indicator appears.)

Accuracy of the electronic linear time counter

The linear time counter provided with this unit is not a clock. The time indicated by the counter may differ slightly from the actual recording/playback time.

Recording level adjustment (for analog input signals only)

The peak level meters show the peak level of the analog input signal held momentarily. The MARGIN indicator shows how much margin there is between the peak level of the input audio signal and 0 dB. Whenever a signal having a higher level than the displayed one is input, the new level replaces the lower one on the MARGIN indicator. Turn REC LEVEL so that the "OVER" segments do not light, even at the highest level.

When adjusting the recording level, set the REC MONITOR switch to SOURCE.

To reset the margin

Press MARGIN RESET. The margin will become "- -".

If the level exceeds 0 dB

The "OVER" segments light in red, and "0.0 dB" blinks. If "OVER" lights steadily, lower the recording level to avoid sound distortion.

If you keep adjusting the recording level with the unit in the record-pause mode

If the unit is left in the record-pause mode for more than 10 minutes, the record-pause mode will be released automatically, and the unit will enter the stop mode. When the REC MONITOR switch is set to SOURCE, the levels of the input audio signals appear even in the stop mode, and you can continue to adjust the recording level. In the above case, press REC again to start recording.

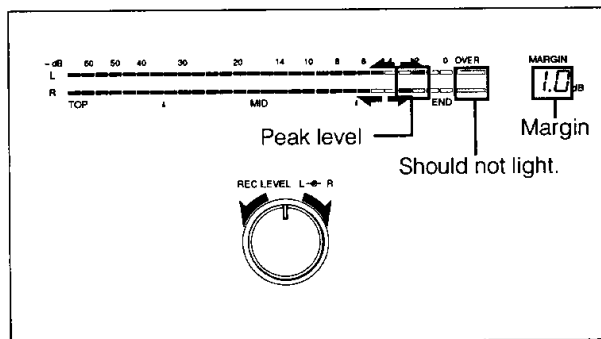

If the digital input signal is interrupted during a digital recording

When the digital unit signal is interrupted by disconnecting the cable or intermitting a broadcast, OPTICAL or COAXIAL appears and the unit enters the pause mode for about 10 minutes. The input of the digital signal resumes in this mode, the unit will enter the recording mode automatically.

Long-play mode

According to the input signal, recording/playback in the long-play mode can be performed as follows.

| Input signal | Recording mode (position of the REC MODE selector) | |
|--|--|--|
| | STANDARD | LONG |
| Analog input signal | standard play (48 kHz) | long play (32 kHz) |
| Digital input signal 32 kHz* | standard play (32 kHz) | long play (32 kHz) |
| Digital input signal 44.1 kHz, 48 kHz* | standard play (the same as input signal) | standard play (the same as input signal) |

() : sampling frequency

The digital input signal on 44.1 kHz or 48 kHz cannot be recorded/played back in the long play mode, even if the REC MODE selector is set to LONG.

*When analog input signal with 32 kHz or 48 kHz is recorded via digital-to-digital connection.

The longest recording period at each mode

| Cassette / Mode | The longest recording period | |
|-----------------|------------------------------|-------|
| | standard | long |
| DT-120 | 2h | 4h |
| DT-90 | 1h30m | 3h |
| DT-60 | 1h | 2h |
| DT-46 | 46m | 1h32m |

(h: hour, m: minute)

The timer counter in the long-play mode

Tape running time, absolute time and total remaining of the tape appears, based on those in the standard mode. To obtain the actual time, double each value.

Creating a Sound Muted Portion (Record Muting)

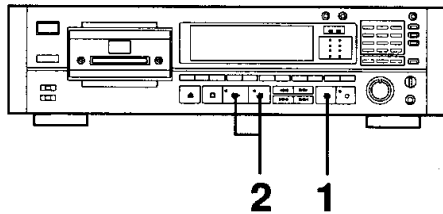

1 During recording or record-pause mode, press REC MUTE where a sound muted portion is required.
The REC indicator blinks and the record muting is activated. After about 4 seconds, the REC indicator shows a steady light, and the 8 indicator lights. The deck enters the record-pause mode.

2 To resume recording, press PAUSE or ►
Recording resumes.

Using sound muted portion

If you intend to dub the DAT cassette onto an analog cassette tape, we recommend that you insert sound muted portions between selections on the DAT cassette. This will ensure that the AMS function of the analog cassette deck works correctly for the recorded tape.

Note

With DAT deck, the AMS function is realized by using the start ID code. (See page 26.)

Caution

To place a space on a DAT cassette, you must not advance the tape with ►► or ►. If a space is created this way, no absolute time code will be recorded on the succeeding area, and there will be no operation using the absolute time codes (time search operation, page 34).

To create a sound muted portion of more than 4 seconds

Keep REC MUTE pressed for as long as you want to make a recorded portion with no signals. After about 4 seconds, the indicator blinks rapidly. When you release REC MUTE, the deck enters the record-pause mode. The interval between selections is indicated in the MARGIN display.

To create a sound-muted portion of less than 4 seconds

Press REC MUTE, and then ■■ while the REC indicator is blinking.

To record in the REC MUTE mode

Press ● while the REC indicator is blinking.

End Search

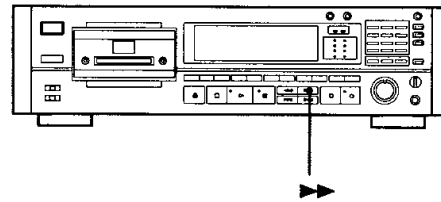

If the previous recording was applied to the middle of the tape, you must locate exactly the last point of the recorded area, and start the new recording from this point. This will prevent leaving a blank section on the tape. If you want space between the last recording and the new recording, use the REC MUTE button to mute the sound.

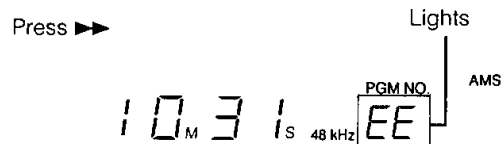

The last point of the previous recording (the beginning of the blank section or the beginning of the end ID*) is located, and the tape stops. When the end ID is detected, the EE indicator lights.

Note

If the point where you pressed ►► is blank, the end search operation will not function.

- If the end ID is written before the blank section, the end search operation stops at the beginning of this end ID.

Note on the duration of a blank section

The blank section must last for more than 9 seconds for the end search operation to function correctly.

Fade-in/Fade-out Recording

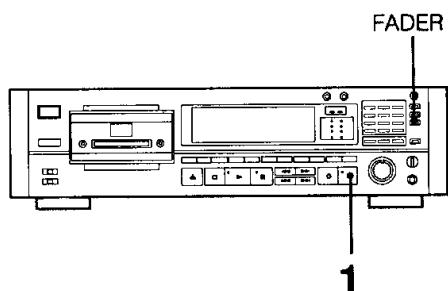

Fade-in Recording

- 1 Press REC at the starting point of recording.**
The deck enters the record-pause mode.
- 2 Press FADER at the point where you want to start fading in.**
The FADE IN indicator blinks, and the sound fades in.

To get the original sound level during a fade-in recording

Press ●.

To get the original sound level during a fade-out recording

Press ■.

Fade-out Recording

Press FADER at the point where you want to start fading out.

The FADE OUT indicator blinks, and the sound being recorded fades out.

A countdown starts, and the deck enters the record-pause mode after the 0.0s indicator appears.

To designate a desired duration of fade-in/fade-out

You can designate a desired duration of fade-in/fade-out, from 0.2 seconds to 15 seconds. Fade-in/fade-out is performed in 5 seconds unless you designate a different duration.

If you turn off the unit after designating the desired duration of fade-in/fade-out, the duration remains memorized.

- 1 Choose either FADE IN or FADE OUT by pressing FADER in the stop mode.**
- 2 Designate a desired duration by pressing ◀◀ or ▶▶.**
Each time pressing ◀◀ or ▶▶, a duration in the display changes as follows:
from 0.2 sec. to 3.0 sec.: in 0.2 sec. intervals
from 3.0 sec. to 5.0 sec.: in 0.4 sec. intervals
from 5.0 sec. to 15 sec.: in 1 sec. intervals.

CD Synchronized Recording

If a Sony Compact Disc player with a Remote Commander is available, you can start playback of the CD player and the recording of the DAT deck, using the Remote Commander.

Position the Remote Commander so that the signal reaches the remote sensor of both the DAT deck and the CD player.

To start recording

Use the Remote Commander of the DAT deck.

- 1 Insert a cassette.**
- 2 Insert the disc in the CD player.**
- 3 Press CD SYNCHRO STANDBY on the Remote Commander of the DAT deck.**
The deck enters the record-pause mode.
- 4 Press CD SYNCHRO START on the Remote Commander of the DAT deck.**
Recording on the DAT deck starts, and about 1 second later, playback of the CD player starts.

To stop recording

Press CD SYNCHRO STOP on the Remote Commander of the DAT deck.

Note

To momentarily stop recording of the DAT deck and playback of the CD player, press the ■ buttons on both the DAT deck and the CD player.

To control the CD player with the Remote Commander of the DAT deck

The following operations are possible:

Playback... Press ■ twice.

Pause... Press ■ once.

AMS... Press ◀◀ or ▶▶.

When a desired selection is located using the above operation, you can start CD synchronized recording.

CD operating buttons

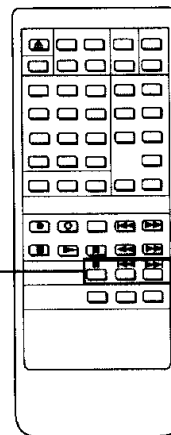

Sub Codes

In addition to the ordinary audio signals, various control codes called sub codes can be recorded on the DAT cassette tapes to ease recording and reproducing operation.

A desired selection can be called up or time information can be displayed using the sub codes, for example. The sub codes, start ID, program number, skip ID, end ID, program time, absolute time and date function (recording the date) are available on this unit.

- Sub codes are written on the tape separately from the audio signals, so the audio signals are not affected. (Refer to "Technical Information" on page 43 for more details.)
- Sub codes, except the absolute time and the date function, can be rewritten after the audio signal recording has been completed. The recorded audio signals are not affected by the rewritten sub codes.

- When you record the tape with sub codes written onto a new tape via digital-to-digital connection, the sub codes to be written on the new tape are following:

| | |
|-----------------|---|
| Start IDs | The same as the codes written on the original tape. |
| Skip IDs | The same as the codes written on the original tape. |
| Program Numbers | New ones will be written according to the DAT deck you use. |
| Absolute time | New ones will be written. |
| End ID | The one written on the original tape will not be written. |
| Date function | The one written on the original tape will not be written. |

When you use analog-to-analog connection, no sub codes on the original tape will be written onto a new tape. New codes will be written according to the DAT deck you use.

Start ID

This signal indicates the start of a music selection. You can locate the position of the start ID precisely. This signal should be written at the beginning of the selection.

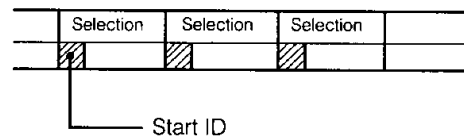

Program number

This signal gives a number to selection. You can record it where the start ID is written. By designating this number, you can choose the desired selection directly or program selections in a desired order.

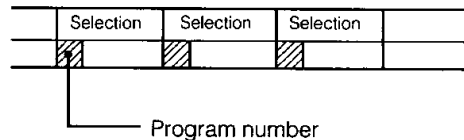

Skip ID

This signal can be marked on the selection wherever you wish. When the SKIP PLAY indicator is lit during playback, the deck will skip at high speed from where the skip ID is marked to the next start ID, and then playback will start again. Record this skip ID at the beginning of portion you want to skip.

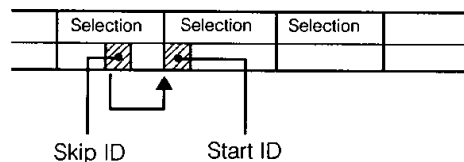

End ID

This signal indicates the end position of a recording.

- ① When you do not want to listen to the very end of a tape, record the end ID at the beginning of the portion you do not want to be played. When the end ID is detected during playback, the tape stops automatically.
- ② When recording new material on a recorded tape, you can write an end ID at the end of the re-recorded portion. This will help you easily find the position to start recording the next time when you want to record other material onto the same tape.

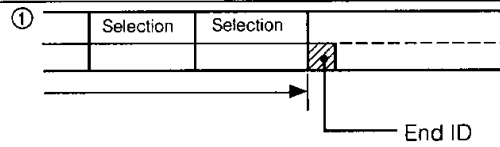

During playback, the tape is automatically rewound to the beginning.

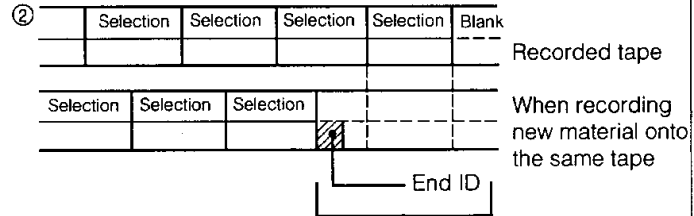

Portion where you have not made a second recording (This first recording has not been erased.)

Absolute time

The absolute time indicates the position of the tape, giving the time elapsed from the beginning. The absolute time is recorded automatically at the same time the audio signal is recorded. It cannot be re-recorded. The absolute time allows you to confirm the elapsed time from the beginning of the tape, or search for the position of the tape you want to listen to.

Program time

This is the time elapsed for a selection.

The date function (Recording a date)

With the built-in clock, the date and time of recording are automatically recorded.

When using the sub codes

| Things that can be done | Required sub code(s) |
|--|--------------------------------------|
| Locating a selection (AMS function) | Start ID |
| Listening to the first portion of selections sequentially (Music Scan) | Start ID |
| Choosing a selection directly | Start ID/Program number |
| Programming desired selections in a desired order (RMS play) | Start ID/Program number |
| Skipping the portion not desired | Skip ID/Start ID |
| Knowing the correct elapsed time of playback | Absolute time |
| Starting the playback from the desired place | Absolute time |
| Looking for the position at which the recording or playback ends | End ID |
| Play a desired portion repeatedly (A-B repeat function) | Absolute time |
| Locating a selection by designating the time (Time search function) | Absolute time |
| Check the recording date and time | Date (It is recorded automatically.) |

Start ID

The start ID indicates the beginning of each selection. You can start playback from the start ID position. (See page 21 for details.)

There are three ways to write start ID:

- Writing automatically during recording
- Writing manually at the desired position during recording
- Writing manually at the desired position playback

Note

While the start ID is being written, all buttons except ■ and OPEN/CLOSE are not operative.

Writing Automatically During Recording

1 Make sure that the AUTO indicator is lit. If it is not press START ID AUTO.

When turning on the power and inserting a cassette with its safety tab at the record-possible position, AUTO lights. In time recording, this indicator will be the same as the one before the power is turned off. Start IDs will be recorded automatically when the AUTO indicator lights.

2 To start recording, press REC, then press PAUSE or ► (play)

When the non-signal level lasts for more than 3 seconds and a selection then starts, the start ID is written for 9 seconds (18 seconds in the long-play mode).

While a start ID is being written, the START ID indicator blinks.

Why 9 seconds or 18 seconds are necessary for writing a start ID

A start ID required 9 or 18 seconds to allow to be detected when rewinding/fast-forwarding a tape. (The speed is 200 times as fast as that of normal tape operation.)

After the start ID is located, the tape returns to the beginning of the start ID if necessary, and playback starts from the beginning of the selection.

If the signal level stays very low for more than 3 seconds

If there is a portion of very low volume level during a selection, a start ID may be written even in the middle of the selection. An unwanted start ID can be erased later. (See page 27).

When the portion between selections is not clear

The start ID position may not coincide exactly to the beginning of the selection. To shift the start ID position, see "Shifting Start IDs' and Program Numbers Position" on page 29.

Illustration of writing a start ID

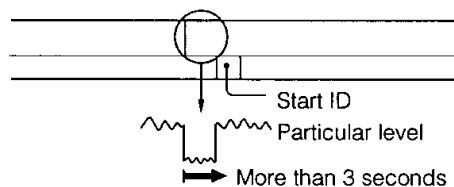

When recording from a CD player

If the auto space function is available with your CD player, activate this function to ensure that the start IDs are written correctly.

Writing Manually During Recording

- 1 Make sure that the AUTO indicator is off. If it is not, press START ID AUTO to turn it off.**
- 2 To start recording, press REC, then press PAUSE or ► (play).**
- 3 At the desired position, press START ID WRITE.**
The start ID is written for 9 seconds (18 seconds in the long-play mode) from the point where you pressed START ID WRITE. While a start ID is being written, the START ID indicator blinks.

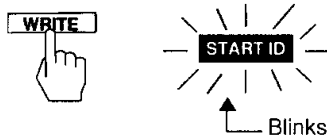

Writing Manually During Playback

During playback, start ID can be written at the desired position more accurately than during recording.

- 1 Press ► to start playback. At the desired position, press START ID WRITE.**
The REHEARSAL indicator lights, and the position for 3 seconds from the point where you pressed START ID WRITE, is played back repeatedly (rehearsal function). The beginning of the repeated portion will be the beginning of the start ID.
- 2 Press ◀◀ or ▶▶ to adjust the "repeat start" point.**
The "repeat start" point is shifted backward with ◀◀ or forward with ▶▶, by about 0.3 of a second. The indicator at the MARGIN shows how much the "repeat start" point is shifted from the point where you pressed START ID WRITE. It can be shifted up to 99 seconds backward or forward.
- 3 After setting the beginning of the start ID at the desired point, press START ID WRITE again.**
The WRITE indicator lights steadily and the start ID is written. The program number is not written.

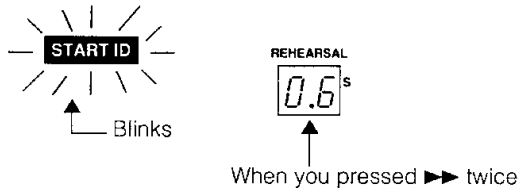
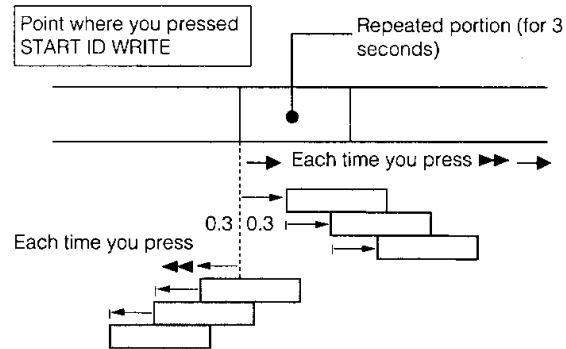

Illustration of the rehearsal function



The repeated portion is played back 16 times, and the tape stops.

Adjusting the Position

To finely adjust the position of a start ID written automatically during recording, use the rehearsal function described on the left column.

You can shift the start ID position about 2 seconds backward or forward. The shift it for more than 2 seconds, first erase the start ID (see below) and rewrite it manually.

- 1 During playback, press START ID WRITE where the start ID to be shifted is written.**
- 2 Perform steps 2 and 3 described on the left column, "Writing Manually During Playback."**

Erasing

While the start ID you want to erase appears in the display during playback or in the stop mode, press START ID ERASE.

That start ID is erased.

The ERASE indicator blinks while the start ID is detected. While the start ID is being erased, the ERASE indicator lights and the START ID indicator blinks.



If you press START ID ERASE during the stop mode or while the START ID indicator is not in the display
The start ID just before the current position is erased.

When a start ID is erased

If a program number is also written with the start ID, both codes will be erased at the same time.

Program Numbers

Program numbers are the codes indicating the selection order. (See page 24 for details.)

There are two ways to write program numbers:

- Writing automatically during recording
- Renumbering automatically during playback or in the stop mode

Writing Automatically During Recording

When you proceed so that start IDs are written automatically during recording, the program numbers are also written.

Writing program numbers from the beginning

1 The AUTO Indicator must be lit. If it is not, press START ID AUTO.

When turning on the power and inserting a cassette with its safety tab at the record-possible position, the AUTO indicator lights. In timer recording, the AUTO indicator will be the same as the one before the power is turned off.

2 To start recording, press REC, then press PAUSE or ► (play).

The program numbers will be written in numerical order from "1" at the same position as the start IDs.

Writing program numbers from the middle of the tape

1 The AUTO Indicator must be lit. If it is not, press START ID AUTO.

When turning on the power and inserting a cassette with its safety tab at the record-possible position, the AUTO indicator lights.

In timer recording, the AUTO indicator will be the same as the one before the power is turned off.

2 If you are aware of the program number of the last selection, go to step 4. If you are not aware of the program number, locate the last point of the previous recording, using the end search function. (See page 22.)

3 Press ►, then press ◀◀.

The last selection is played, and its program number appears at the PGM NO. indicator position.

4 Locate the last point of the previous recording, using the ►► button. (See page 22.)

It is important to proceed with the end search in order not to leave a blank section on the tape.

5 Press REC to set the deck in the record-pause mode.

6 Designate the next program number (the number that follows the program number of the last selection) with the numeric button.

If the program number of the last selection appears at the PGM NO. indicator position, you need not designate the next number.

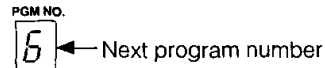

7 Press PAUSE or ► (play).

The program numbers are written consecutively, beginning from the designated number.

If the next program number is not designated

The start IDs will be written, but the program numbers will not.

You can write the program numbers using the renumbering function described on the next page.

Renumbering

If you record from the beginning to the middle of a tape on which another recording has ever been applied, the same program number may be written twice on that tape. If you omit designating the next program number when recording from the middle of the tape, the succeeding program numbers are not written. In such cases, proceed as follows to renumber the program numbers from the beginning of the tape at a high speed.

Renumbering Program Numbers Automatically

- 1 Make sure that the AUTO indicator is lit, and that the safety tab of the cassette is at the record-possible position.**

If the AUTO indicator is not lit, press START ID AUTO.

- 2 Press RENUMBER during playback or in the stop mode.**

The tape will automatically be rewound to the beginning, and the program numbers are rearranged from "1" in numerical order at each start ID position.

While the program numbers are rewritten, the START ID indicator blinks and while the tape is fast-forwarded to the next start ID the RENUMBER indicator blinks.

When program numbers are written correctly, the tape is fast-forwarded to the next start ID.



When renumbering is terminated

The tape is automatically rewound to the beginning, and the deck function stops.

Shifting Start IDs' and Program Numbers Position

The start ID position may not coincide exactly to the beginning of the selection, especially when the portion between selections is not clear. On such a tape, the very beginning of the selection cannot be located using the AMS function. If this happens, you can shift the start ID and program number position, however, you cannot shift the position of the program number 1.

- 1 Make sure that the AUTO indicator is off, and that the safety tab of the cassette is at the record-possible position.**

If the AUTO indicator is lit, press START ID AUTO.

- 2 Press RENUMBER during playback or in the stop mode.**

The start ID and program number position of the 2nd selection, and the succeeding selections, will be shifted forward by about 0.3 of a second.

When program numbers are written incorrectly, the renumber function operates.



Erasing

During playback, press START ID ERASE while the program number to be erased appears in the display window.

That program number is erased. The start ID at the same position will also be erased.

The ERASE indicator blinks while the program number is being searched for, and the START ID indicator lights while the program number is being erased.



When the program number is erased

Playback continues. The succeeding program numbers remain unchanged. To rearrange the program numbers, renumber them as described on the left column.

Skip ID

When the skip ID is detected during playback, the tape skips to the next start ID position, and the normal playback resumes. (See page 24 for details.)

Writing During Recording

Press SKIP ID WRITE at the beginning of the portion you want to skip later.

The skip ID is written for about 1 second (2 seconds in the long-play mode) from where you pressed the button.

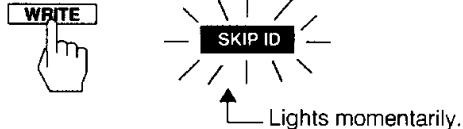

Writing During Playback

During playback, skip ID can be written at the desired position more accurately than during recording.

1 During playback, press SKIP ID WRITE at the desired position.

The REHEARSAL indicator lights, and the portion for 3 seconds to the point where you pressed SKIP ID WRITE, is played back repeatedly (rehearsal function).

The end of the repeated portion will be the beginning of the skip ID.

2 Press ◀◀ or ▶▶ to adjust the "repeat end" point.

The "repeat end" point shifted backward with ◀◀ or forward with ▶▶, by 0.3 of a second.

The indicator at the MARGIN shows how much the "repeat end" point is shifted from the point where you pressed SKIP ID WRITE.

It can be shifted up to 99 seconds backward or forward.

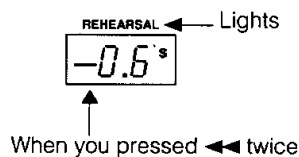

3 After setting the beginning of the skip ID at the desired point, press SKIP ID WRITE again.

The SKIP ID indicator lights, and the skip ID is written.

Note on the point where a skip ID is written

During rehearsal function, a skip ID will be written at the end of the repeated portion as illustrated.

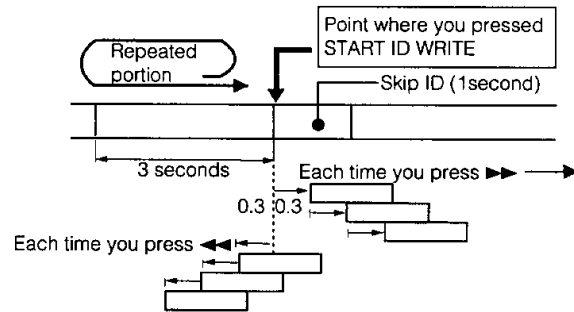

The repeated portion is played back 16 times, and the tape stops.

Erasing

During playback or in the stop mode, press Skip ID ERASE immediately after the skip ID to be erased.

The tape is rewound to the nearest skip ID position and the skip ID is erased.

The ERASE ID indicator lights while the skip ID is being erased and goes off when the skip ID is erased.



Precaution

When the skip ID and the start ID are overwritten, the skip ID will also be erased if the start ID is erased.

| ID to be erased | Operation |
|-------------------|-----------------------|
| Start ID, skip ID | Press START ID ERASE. |
| Skip ID | Press SKIP ID ERASE. |

End ID

The end ID indicates the last position of the recording or playback. While recording on the same tape has been done several times, you can locate the point where the previous recording terminates quickly, using the end ID. When the end ID is detected during playback, the playback stops automatically.

Writing During Recording

1 Press PAUSE, REC MUTE or FADER.

| The button you pressed | The mode of the deck |
|------------------------|---|
| PAUSE | Record-pause mode |
| REC MUTE | Record-pause mode after a sound muted portion is created for 4 seconds. |
| FADER | Record-pause mode after the sound fades out. |

2 Press END ID WRITE.

The END ID WRITE indicator lights.

3 Press PAUSE or ► (play) to release the record-pause mode.

The END ID indicator lights.

The end ID is written for about 9 seconds (18 seconds in the long-play mode). Tape returns to the beginning of the end ID after the end ID is written.

After you write an end ID

The portion after the end ID position cannot be played back (EE appears in the PGM NO. display.)

Erase the end ID (page 32) where you want to play back the portion after the end ID position.

Writing During Playback

During playback, no end ID can be written on a blank section.

1 During playback, press END ID WRITE at the desired position.

The REHEARSAL indicator lights, and the portion for 3 seconds to the point where you pressed END ID WRITE, is played back repeatedly (rehearsal function).

The end of the repeated portion will be the beginning of the end ID.

2 Press ◀◀ or ▶▶ to adjust the "repeat end" point.

The "repeat end point is shifted backward with ◀◀ or forward with ▶▶, by 0.3 of a second.

The indicator at the MARGIN shows how much the "repeat end" point is shifted from the point where you pressed END ID WRITE.

It can be shifted up to 99 seconds backward or forward.

3 After setting the beginning of the end ID at the desired point, press END ID WRITE again.

The EE, END ID and WRITE indicators light, and an end ID is written.

Note on the point where an end ID is written

During rehearsal function, an end ID is written at the end of the repeated portion as illustrated.

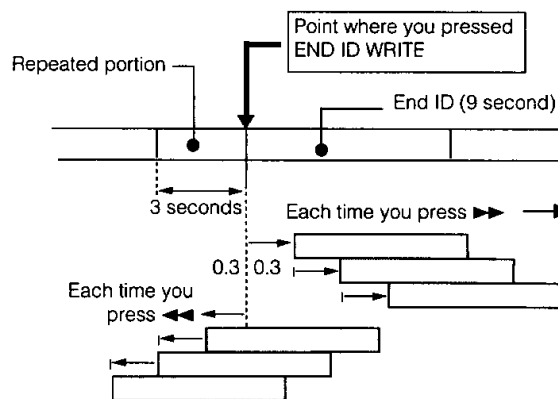

The repeated portion is played back 16 times, and the tape stops.

Erasing

- 1 Search for the beginning of the end ID with the ►► button. (See page 22.)**
When the end ID is detected, "EE" lights.
- 2 Press END ID ERASE.**
The END ID ERASE indicator lights while the end ID is being searched for and then goes off when the end ID is erased.
If you want to start recording from the point where the end ID is written, you need not press END ID ERASE.

Playback

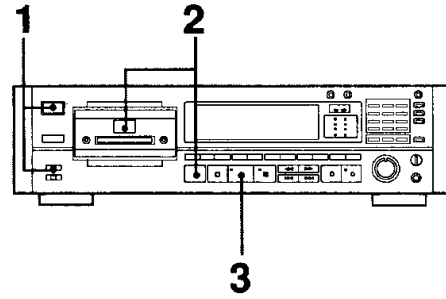

- 1 Make sure that TIMER is set to OFF, and then turn on the power.**
- 2 Insert the cassette and press ▲ to load the cassette.**
- 3 Press ►.**
Playback begins.
If an end ID is written on the tape, playback stops automatically at the end ID position, and the tape will be rewound to the beginning.

To control tape transport

| | |
|---------------------------------------|-----------------------------------|
| To stop playback | Press ■. |
| To stop playback for a moment | Press ■■. |
| To release pause and restart playback | Press ■■ or ►. |
| To remove the cassette | Press ▲. |
| To rewind or fast-forward the tape | Stop the tape and press ◀◀ or ▶▶. |

Cue/review operation

| | | |
|---------------------------|---------------------------|--|
| To advance the tape (cue) | Press ►► during playback. | Sound is heard while the button is pressed. Release the button at the desired point. Playback resumes. |
| To review the tape | Press ◀◀ during playback. | |

The speed of the tape increases 4 seconds after the cue or review starts.

Display Window

Each time you press COUNTER MODE, the counter changes as follows.

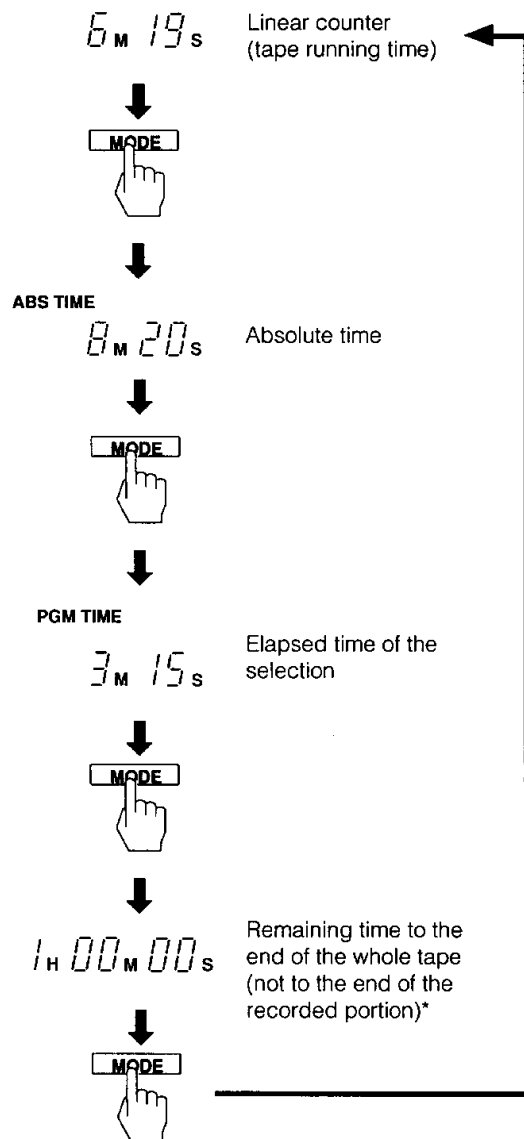

Notes

- At the beginning of the tape, "FF" may appear and immediately go off at the PGM NO. indicator position depending on some types of pre-recorded tapes. ("FF" stands for "beginning".)
- To reset the counter to 0M 00S, press RESET.
- When playing back a pre-recorded tape (software), remaining time to the end of the recorded portion appears.

To check the sampling frequencies recorded on the tape — Frequency Map

Press 4 on the music selector while keeping COUNTER MODE pressed.

Bars on the level meter light to signify the sampling frequencies with which the material was recorded. (No bars light until 16 seconds after playback starts.)

| Sampling frequency | Level meter to be lit |
|--------------------|---------------------------|
| 32 kHz | Upper bar |
| 44.1 kHz | Both upper and lower bars |
| 48 kHz | Lower bar |

"TOP", "MID" and "END" indicate the beginning, middle and end of each tape respectively.

Example:

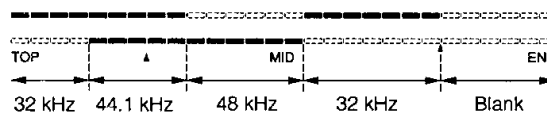

Elapsed time of the selection does not appear when...

- The selection is played back from the middle.
- The tape is being fast-forwarded or rewound.
- The cassette compartment is opened or closed by OPEN/CLOSE.

Adjusting the headphones volume

Use the PHONE LEVEL control.

When the tape is played back to its end

The tape will be rewound to the beginning and stop automatically.

Remaining time does not appear in the following cases

- Immediately after the deck is set in the playback mode. The remaining time will appear about 16 seconds later.
- When playback is started from a blank section (page 18), the remaining time may not appear. Press ◀◀ or ▶▶.

Accuracy of the indicator for the remaining time

According to the kind of tape, the indicated time may differ slightly from the actual remaining time.

If tape noise exists, or sound quality has deteriorated

The head may be contaminated. Clean the head, using a cleaning cassette (See page 41).

When the EMPHASIS indicator appears

When playing back the portion with emphasis, the built-in de-emphasis circuit lowers the high frequency level automatically.

On the REC MONITOR switch

During playback, the tape sound is selected regardless of the switch position. However, at the SOURCE position, the program source is automatically selected when the playback stops.

Auto Play: Restarting Playback after Rewinding

While pressing ◀◀, press ▶. The tape is rewound to the beginning, and playback starts automatically.

If the above operation is done immediately after the cassette is inserted, the auto play operation does not function. Press ▶ a few seconds after ◀◀ is pressed.

Time Search: Fast-forwarding/Rewinding the Tape by Designating the Amount in Minutes

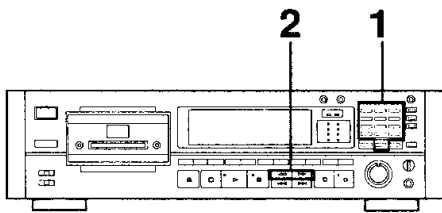

The time search function is available only for the tape portion where the absolute time code (page 18) is written.

1 Designate how much you want to advance the tape forward or backward in minutes, using the numeric buttons.

An amount in minutes can be set from 1 minute to 99 minutes. Designating the amount in seconds is not possible.

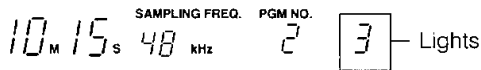

2 Press ▶▶ to advance the tape forward, and ◀◀, backward.

The tape is fast-forwarded or rewound, stops at the designated position, and playback resumes.

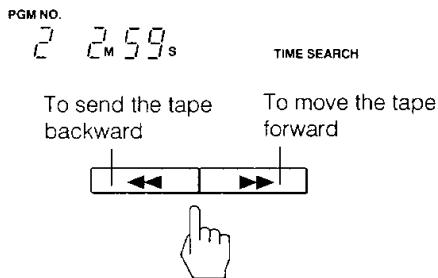

* When ◀◀ or ▶▶ is pressed in pause mode, the tape stops at the desired position in pause mode.

Time Search: To start playback by designating the elapsed time from the beginning of a tape

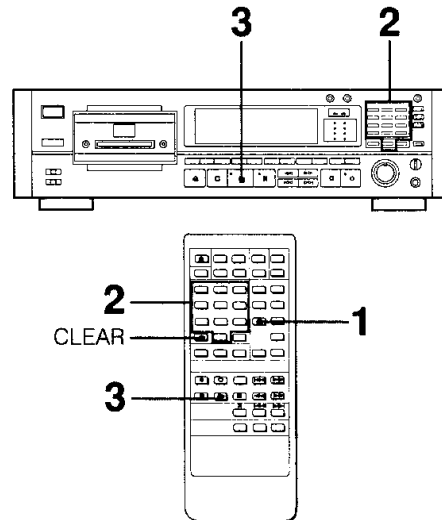

The time search function is available only for the tape portion where the absolute time code (page 18) is written.

This operation can be performed only with the Remote Commander.

1 Press the TIME SEARCH button on the remote commander.

The Hour, Minute and Second indicators appear on the display.

2 Designate the time of the desired location from the beginning of the tape.

When designating 1 hour and 15 minutes and 8 seconds.

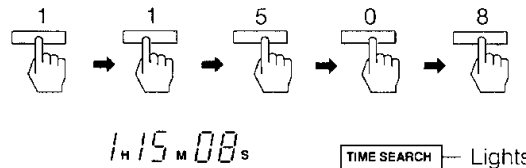

3 Press ▶.

The tape is fast-forwarded or rewound, stops at the designated position, and playback resumes.

* When ▶ is pressed in pause mode, the tape stops momentarily at the desired position.

When designating just 3 minutes

Press the numeric buttons in the following order: 0 → 0 → 3

If you press the incorrect button when designating
Press the CLEAR button. The position to be designated returns to the previous one.

Various Playback Operations

Fade-in/Fade-out Play

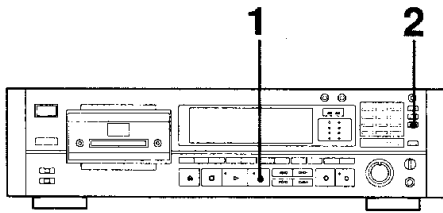

Fade-in/fade-out play cannot be performed through the digital output jack.

Fade-in Play

- 1 During playback or in the stop mode, press PAUSE.**
The deck enters the pause mode.
- 2 Press FADER.**
The FADE IN indicator blinks, and the sound fades in.

Fade-out Play

During playback, press FADER at the point where you want to start fading out.

The FADE OUT indicator blinks, and the sound being played back fades out.
A countdown starts, and the deck enters the pause mode after the 0.0s indicator appears.

To designate a desired duration of fade-in/fade-out

You can designate a desired duration of fade-in/fade-out, from 0.2 seconds to 15 seconds.
Fade-in/fade-out is performed in 5 seconds unless you designate a different duration.
If you turn off the unit after designating the desired duration of fade-in/fade-out, the duration is reset to 5 seconds.

- 1 Choose either FADE IN or FADE OUT by pressing FADER during the stop mode.**
- 2 Designate a desired duration by pressing ◀◀ or ▶▶.**
Each time pressing ◀◀ or ▶▶, a duration in the display changes as follows:
from 0.2 sec. to 3.0 sec.: in 0.2 sec. intervals
from 3.0 sec. to 5.0 sec.: in 0.4 sec. intervals
from 5.0 sec. to 15 sec.: in 1 sec. intervals

Repeat Play

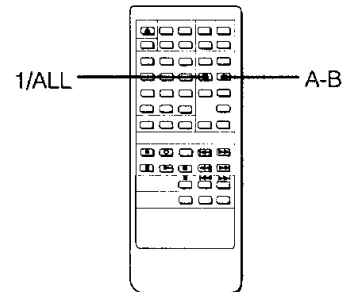
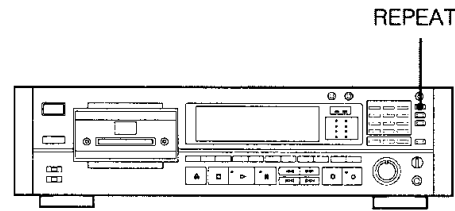

Playing a Selection Repeatedly

Press REPEAT (1/ALL on the Remote Commander) while the desired selection is played back.

"REPEAT 1" appears.

After the selection is playback, the tape is rewound to the beginning of that selection, and the playback is repeated.

To stop playing a selection repeatedly

Press REPEAT (1/ALL on the Remote Commander) until "REPEAT 1" goes off.

Note on the end of the repeated portion during "REPEAT 1" play

The tape is rewound to the beginning of the selection to be repeated when one of the following is detected.

- Start ID of the next selection
- A blank section of more than 9 seconds
- End of the tape
- Skip ID with SKIP PLAY activated

Number of times to be repeated

The selection to be repeated will be played back 16 times, and then the tape will stop.

Playing all selections repeatedly

During playback, press REPEAT (1/ALL on the Remote Commander) until "REPEAT ALL" appears in the display.

After the tape is played back to the end, it is rewound to the beginning and the playback of all selections is repeated. In the RMS play (page 39), all the selections programmed are played back repeatedly.

Repeat Play

To stop playing all selections repeatedly

Press REPEAT (1/ALL on the Remote Commander) until "REPEAT ALL" goes off.

Note on the end of the repeated portion during "REPEAT ALL" play

The tape is rewound to the beginning of the tape when one of the following is detected.

- End ID
- A blank section of more than 9 seconds

Playing a desired portion repeatedly

This function is available only for the tape portion where the absolute time code (page 18) is written.

This operation can be performed only with the Remote Commander.

1 Press A↔B at the beginning of the desired portion during playback.

The REPEAT A indicator blinks, and the portion for 3 seconds from the point where you pressed A↔B, is played back repeatedly (rehearsal function). The beginning of the repeated portion will be the beginning of your desired portion.

2 Press ◀◀ or ▶▶ to adjust the "repeat start" point.

The "repeat start" point is shifted backward with ◀◀ or forward with ▶▶, by 0.3 of a second.

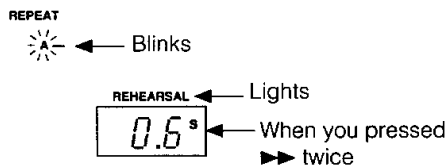

3 After setting the beginning of your desired portion at the desired point, press A↔B again.

The REPEAT A indicator lights.

4 Press A↔B at the end of the desired portion.

"B" of the REPEAT A-B indicator blinks, and the portion for 3 seconds to the point where you pressed A↔B, is played back repeatedly (rehearsal function).

The end of the repeated portion will be the end of your desired portion.

5 Press ◀◀ or ▶▶ to adjust the "repeat end" point.

The "repeat end" point is shifted backward with ◀◀ or forward with ▶▶, by 0.3 of a second.

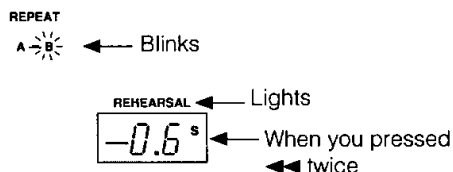

6 After setting the end of your desired portion at the desired point, press A↔B again.

The REPEAT A-B lights, and the designated portion is played back repeatedly.

To stop a desired portion repeatedly

Press A↔B until the REPEAT A-B indicator goes off.

To designate the points A and B without the rehearsal function

Press A↔B immediately after performing the step 1 (point A) and 4 (point B). (With this operation, step 2, 3, 5 and 6 should be skipped.)

Notes on the point of A and B

- If point B is too close to point A, point B may not be set.
- **Be sure to set point A.**
Point B cannot be set before A.

Notes

- You cannot perform the A-B repeat and the time search functions at the same time.
- You may not perform the A-B repeat function with the beginning of the tape.

Illustration of the points of A and B

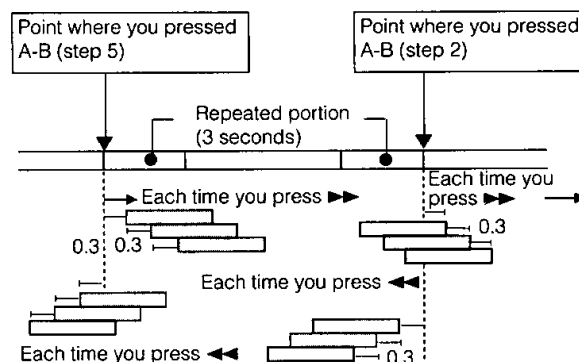

The repeated portion is played back 16 times, and the tape stops.

Automatic Music Sensor Operation

When you press **◀◀** or **▶▶** during playback, playback will start from the beginning of the desired selection.

When it is pressed in the pause mode, the deck enters the pause mode at the beginning of the designated selection. Press **||** or **▶** to resume playback. For this operation, the start ID codes must be written on the tape.

For how to write the start ID, see page 26.

To locate the selection ahead

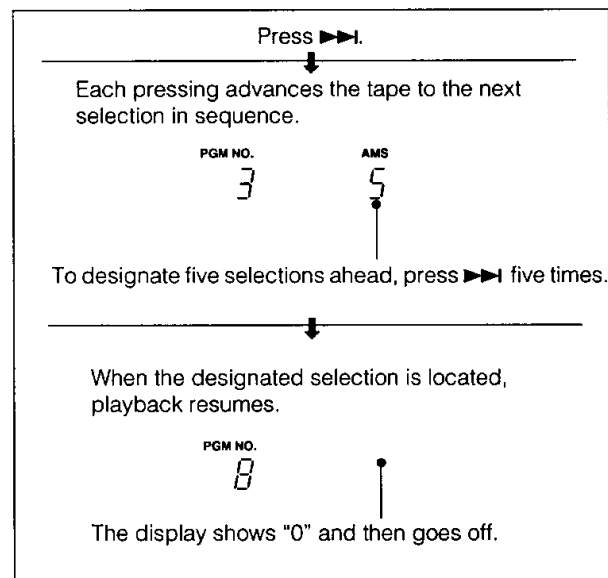

To locate the previous selection

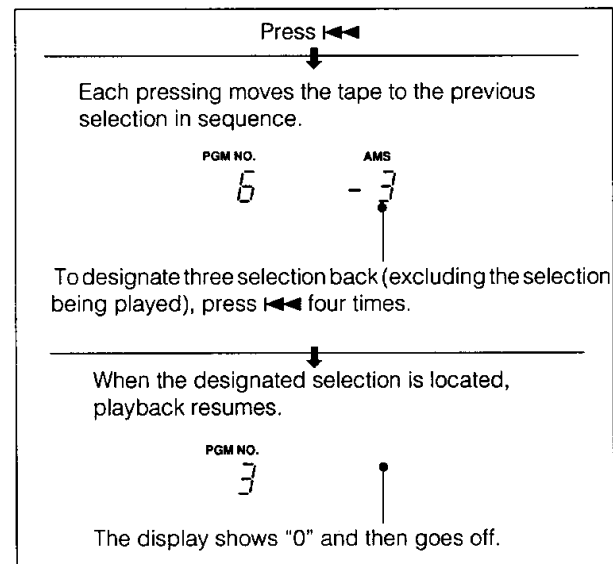

When designating the selection being played back, "-0" appears.

You can designate a selection by pressing the numeric buttons, instead of pressing **◀◀ or **▶▶** several times. In this case, press **◀◀** or **▶▶** after pressing the numeric buttons.**

Music scan

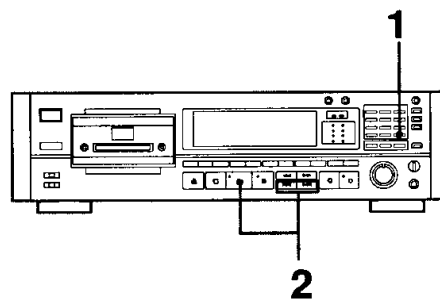

For this operation, the start ID codes must be written on the tape. For how to write the start ID codes, see page 26.

1 During the stop mode, press MUSIC SCAN.

The MUSIC SCAN and the scan time indicators at the FADE blink.

2 Press **▶** (play).

The tape is rewound to the beginning, the first part of each selection (start ID position) is played back for the time you designated sequentially.

The START ID indicator lights during playback.

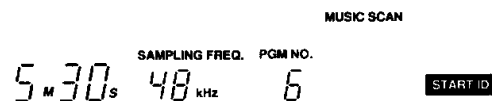

When you press **▶▶** instead of **▶** (play)

The nearest start ID after the current position is detected, and, after playing back the first part of that selection for the time you designated, the next start ID in the forward direction is located.

This operation continues until the end of the tape.

When you press **◀◀** instead of **▶** (play)

The nearest start ID before the current position is detected, and, after playing back the first part of that selection for the time you designated, the next start ID in the reverse direction is located.

This operation continues until the top of the tape.

To designate the desired scan time

While the scan time indicator at the FADE blinks in step 1, press **◀◀** or **▶▶**. You can designate the scan time up to 15 seconds in steps of a second. The scan time is 8 seconds if the scan time is not designated.

Various Playback Operations

To listen to the beginning of a selection for more than the designated time

Press ► (play) while the selection you want to listen to is played back.

While pressing ►, the countdown at the MARGIN indicator stops, and the playback of that selection continues.

To listen to an entire selection

Press MUSIC SCAN while the selection you want to listen to is played back.

The music scan function is released, and the playback of that selection continues.

When you press MUSIC SCAN during playback, the tape is rewound to the beginning, and then the first part of each selection (start ID position) is played back for the time you designated sequentially.

Designating the Desired Selection

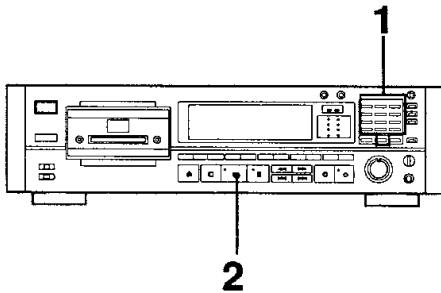

For this operation, the selections must be numbered by the program numbers. The program numbers are written at the same position as the start ID codes. For how to write the program number, see page 28.

1 During the desired program number with the numeric button(s)*.

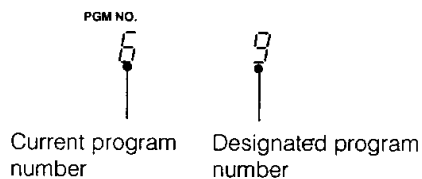

2 Press ► (play).

The designated selection is searched for at high speed and playback starts from the beginning of that selection.

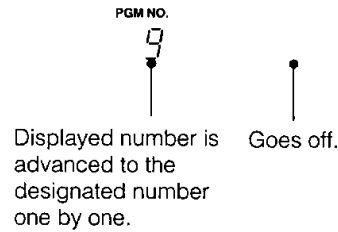

* When you press the numeric button(s) during play-pause mode, the deck enters the pause mode at the beginning of the designated selection. Press ■ or ► to resume playback.

If an incorrect number is designated

Before pressing ►, press CLEAR.

The displayed program number will be cleared.

Then designate the correct program number.

Once ► is pressed, it is impossible to cancel the designated selection.

Skip play

For this operation, the skip ID code(s) must be written on the tape.

Press SKIP PLAY.

The SKIP PLAY indicator lights.

During playback, the tape skips to the next start ID position automatically when a skip ID is detected, and the playback resumes.

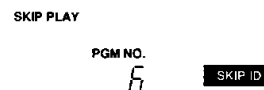

To stop skip play

Press SKIP PLAY to turn the SKIP PLAY indicator.

Random Music Sensor Operation

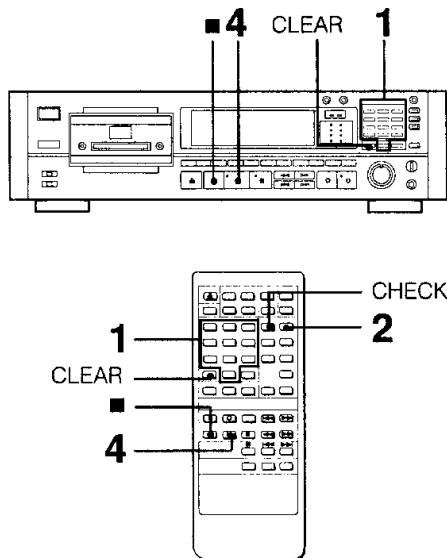

*RMS = Random Music Sensor

The RMS function allows you to program the desired selections in the desired order. For the operation, program numbers must be written on the tape.

This operation can be performed only with the Remote Commander.

- 1 Designate the desired selection by pressing the numeric button(s) during the stop mode.**
The selection numbers can be specified from 0 to 99.

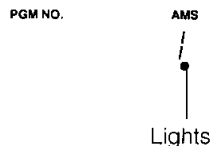

- 2 Press ENTER.**



Indicates the playing order.

The RMS indicator lights after programming the first selection.

- 3 Repeat step 1 and 2.**
A maximum of 60 selections can be programmed.

- 4 Press ►.**
The programmed selections are played back in the designated order.

To stop RMS play

Press ■

To check the programmed selections

Press CHECK on the Remote Commander. Each time you press CHECK, the programmed selections appear in the designated order.

To add a selection to the program

Once the RMS play starts, you cannot add a selection. To add a selection, first stop the RMS play, and program new selection(s) by following the procedure described on the left column.

To delete the selection you programmed last

Press CLEAR.

To cancel the entire program

In the stop mode: Press ■ once.

In the RMS play mode: Press ■ twice.

Timer Activated Operation

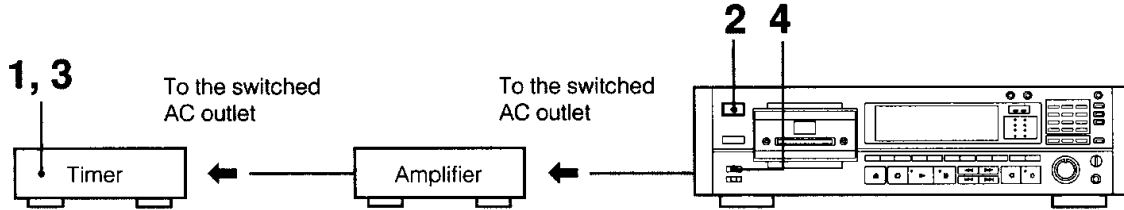

Use a commercially available audio to activate recording or playback at a desired time.
Read the operating instructions for the timer and the amplifier.

Timer Activated Recording

- 1 Turn on the timer.**
- 2 Turn on the DAT deck, and prepare for recording.**
(Follow steps 2, 3, 4 and 6 on page 19.)
- 3 Set the timer to the desired time.**
Power to the amplifier and to the DAT deck is turned off. Leave the power switches of the equipment turned on.
- 4 Set TIMER to REC.**
At the preset time, the power is supplied and recording starts after about 4 seconds.
The AUTO indicator will be the same as the one before the power of the DAT deck is turned off.
When the AUTO indicator lights, start IDs will be written during recording.

When timer activated recording is finished

Be sure to set TIMER to OFF.

Precautions

- If the TIMER switch is left at the REC position, recording will start when the power is turned on the next time, and the tape contents will be erased.
- In timer recording (the TIMER switch is set to the REC position), the auto rewind function will not be activated even if the tape is fully taken up. The tape stops without being rewound so that recording will not be performed over the previously recorded material.
- Be sure to activate timer recording with the cassette inserted properly in the cassette compartment. With the cassette compartment lid opened, timer recording will not function.

Timer Activated Playback

- 1 Turn on the timer.**
- 2 Turn on the DAT deck, and insert the cassette.**
- 3 Set the timer to the desired time.**
Power to the amplifier and to the DAT deck is turned off. Leave the power switched of the equipment turned on.
- 4 Set TIMER to PLAY.**
At the preset time, the power is supplied and playback starts after about 4 seconds.

When timer activated playback is finished

Normally set the TIMER switch to OFF.

If you want to start playback at the preset time every day automatically, leave TIMER to PLAY.

Maintenance

Cleaning the Cabinet

Clean the cabinet, panels and controls with a soft cloth slightly moistened with a mild detergent solution. Do not use any type of abrasive and, scouring powder or solvent such as alcohol or benzine.

Cleaning the Head

Prolonged operation will cause contamination of the head. To make the best possible recording and playback, we recommend cleaning the head periodically, using the DT-10CL cleaning cassette (not supplied).

How to use the cleaning cassette

- 1 Insert the cleaning cassette as you insert a normal DAT cassette.
- 2 Press ►. Press ■ after about 10 seconds.
- 3 Remove the cleaning cassette without rewinding it.
- 4 Proceed with recording and playback with a normal DAT cassette and check the sound quality.

Notes on the cleaning cassette

- The cleaning cassette cannot be used for recording and playback.
- Do not clean the head with the cleaning cassette more than five times over a short period. Cleaning the head continuously for a too long period of time may cause wear to the head.
- Do not rewind the cleaning cassette each time you use it. When the cleaning cassette tape is taken up completely, rewind it to the beginning and re-use it. The cleaning cassette can be used a hundred times, with 10 seconds of cleaning each time. The DT-10CL cleaning cassette is available.

Block Diagram

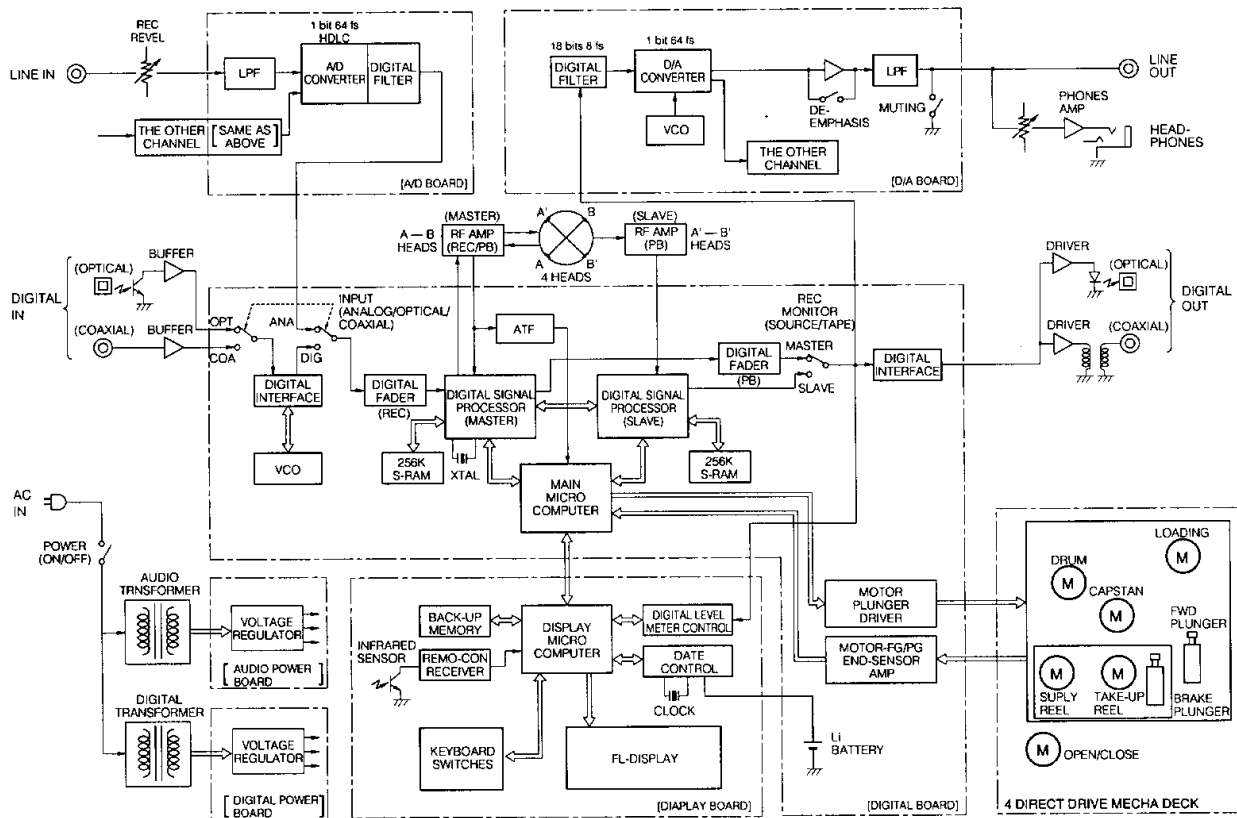

Technical Information

Recording Format of DAT

To record and playback the digital signal converted from the analog signal, a recording/playback system which ensures the frequency range of a few megahertz is necessary. Since this is very difficult for conventional stationary head system, the DAT deck adopted a helical scan system with rotary heads which provides fast relative tape speed. In addition, the DAT uses metal tape. These factors provide a high density recording of 114 Mbit/inch². The DTC-87ES employs a 2-head system with the tape wrapping around 90° for smooth and stable tape transport.

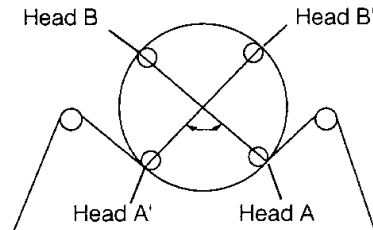

Tape Format and Construction of DAT Cassette

The tape format of DAT and construction of DAT cassette is illustrated below. Although the width of tape is the same as conventional audio cassette tape, the tolerance is very strict as much as +0/-0.02 mm. The cassette shell has sealing mechanism to prevent contamination of the tape.

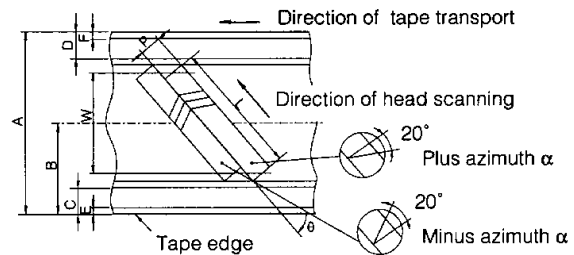

Tape format

| | | 48 kHz mode, 44.1 kHz mode, 32 kHz mode, 32 kHz-LP mode, 32 kHz-4ch mode | 44.1 kHz wide track mode (for contact printing) |
|----------|----------------------------------|--|---|
| A | Tape width (mm) | 3.81 (+0, -0.02) | |
| W | Width of recording area (mm) | 2.613 | |
| L | Track length | 23.501 | 23.471 |
| P | Track pitch (mm) | 13.591 | 20.41 |
| B | Track center (mm) | 1.905 | |
| C | Optional track 1 (mm) | 0.5 | |
| D | Optional track 2 (mm) | 0.5 | |
| E | Edge guard 1 (mm) | 0.1 | |
| F | Edge guard 2 (mm) | 0.1 | |
| θ | Track angle (degrees) | 6°22'59.5" | 6°23'29.4" |
| α | Head gap azimuth angle (degrees) | ±20°(±15') | |

Note

With $\varnothing 30$ (mm) head drum, wrap angle is 90.0°, and still angle is 6° 22'.

Construction of the DAT cassette

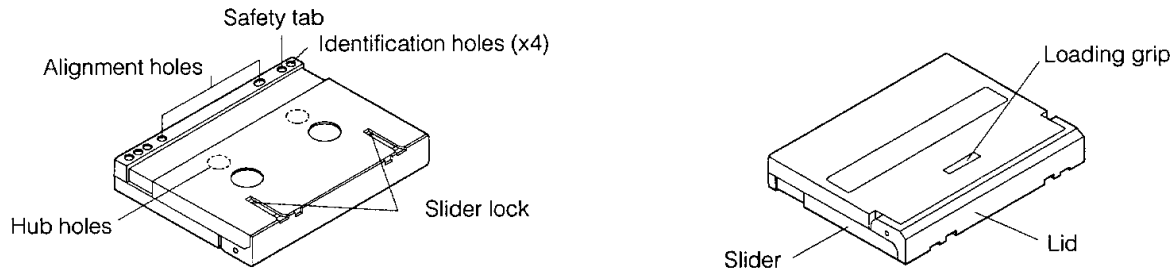

Track Format

DAT can record various kinds of information in addition to the audio signal as illustrated below. Since the information, such as sub-codes are recorded in different areas, it does not affect the audio signal, and enables post edit recording of the data without erasing the audio signal.

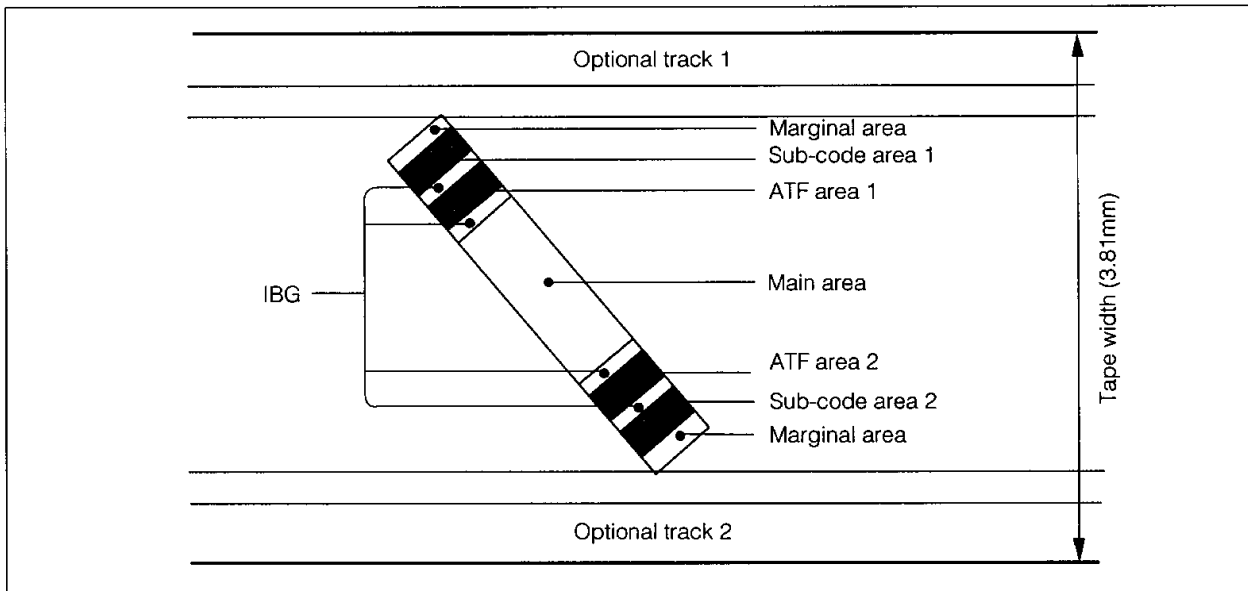

Marginal area

Located on the both margins of the tape for stable contact between the tape and the rotating head. No data is recorded in these areas.

Sub-code area 1 and 2

Sub-codes (start ID, skip ID, and program number) are recorded in these areas. These data are recorded in two areas to avoid burst error, and for easier access during high speed search. The capacity of these areas is about four times of that of a compact disc, and it contains many possibilities for the future.

ATF (Automatic Track Finding/Following) area 1 and 2

The signal for tracking is recorded in these areas. It enables a stable tracking performance of the rotating head.

Main area

The digital audio signal is recorded in this area. In addition to the signal, Main IDs containing the data for sampling frequency, parity bit, etc., are recorded together here.

Troubleshooting

| | Symptom | Cause | Remedy |
|---|--|--|---|
| Basic operation | The tape is rejected after being loaded. | The cassette is inserted incorrectly. | Insert the cassette correctly. (page 17) |
| | The tape does not move. | For 4 seconds after the power is turned on, the buttons do not function. | Wait until the blinking of the II indicator goes off and then try again. |
| | | The PAUSE button is activated. (The II indicator lights.) | Press PAUSE to release pause. |
| | | The tape is wound completely. | Press ◀◀ or ▶▶ button to rewind. |
| | The sound is not heard. | Incorrect connections. | Connect properly. (page 13 and 14) |
| | | Incorrect operation of the connected amplifier. | Operate the amplifier as required by the deck operation. (Refer to the operating instructions of the amplifier.) |
| | | Set the REC MONITOR switch to the TAPE position. | Set to the SOURCE position. |
| | Recording cannot be made. | The safety tab of the cassette is open. | Close the tab of the cassette. (page 17) |
| | | Incorrect position of the INPUT selector. | Set the INPUT selector correctly. Set it to DIGITAL to record sound from the equipment connected to the COAXIAL IN or OPTICAL IN jacks. Set it to ANALOG to record sound from the equipment connected to the LINE IN jacks. |
| | | Set the REC MONITOR switch to the TAPE position. | Set to the SOURCE position. |
| | | The digital copy prohibit signal exists in the source signal input to the digital input jack. | Connect the source equipment to the LINE IN jacks. |
| | The sound is not heard from the recorded tape. | When recording analog input signals, the recording level is turned down completely. (When recording the analog input signal) | Adjust the recording level by using the REC LEVEL controls. (page 21) |
| | The CAUTION indicator lights, and no button does function. | Moisture condenses inside the unit. | Leave the unit as is, then turn on the power. (page 4) |
| | | Defective or damaged cassette is inserted. | Remove the cassette. |
| | Sub code cannot be written. | The safety tab of the cassette is open. | Close the tab of the cassette. (page 17) |
| Start ID cannot be written during recording. | A new start ID cannot be written within 9 seconds (18 seconds in the long-play mode) from the end of another start ID. | Leave at least 9 seconds (18 seconds in the long-play mode) from the end of another start ID. | |

| | Symptom | Cause | Remedy |
|--------------------------------|--|---|---|
| Sub code operation | Search function does not activate during playback. | The start ID is not written correctly. | Erase it (page 27), and then write it again. |
| | | The portion between the end of a start ID and the beginning of the following start ID is less than 9 seconds (18 seconds in the long-play mode) long. | When writing the start IDs manually, write so that the intervals between them are more than 9 seconds (18 seconds in the long-play mode.) |
| | | The selected program number does not exist on the tape. | Use the RENUMBER button to rearrange the program numbers. (page 29) |
| | | The program numbers are out of order. | |
| | Search function activates suddenly during playback. | The skip play function is operating. (The SKIP PLAY indicator lights in the display window.) | Turn off the indicator by pressing SKIP PLAY. |
| | | The repeat play function is operating. (The REPEAT 1, REPEAT ALL or REPEAT A-B indicator lights in the display window.) | Turn off the indicator by pressing REPEAT or A ↔ B. |
| | Search function stops. | There is a blank section between selections. (The sampling frequency indicator blinks on the display window.) | Use the end search function (page 22) when recording so that no blank is created. |
| | The tape operation buttons do not operate while the start ID. | While writing the start ID (9 seconds or 18 seconds), none of the buttons except ■ and OPEN/CLOSE buttons operate. | Operate after the start ID is written. |
| | The absolute time codes cannot be written. | Recording was started from the blank section. | Rewind the tape to the beginning, or locate the very last point of the previous recording, using the end search function (page 22), and start recording from the point. |
| | The time search function does not operate. | Absolute time codes are not written on the tape. | Locate a blank section using the end search function (page 22) and start recording from that point. |
| | | The amount of the designated time exceeds the amount available to the beginning or the end of the tape. | Reduce the amount of the designated time. |
| | The points of A and/or B for the repeat play cannot be set. | Absolute time codes are not written on the tape. | Locate a blank section using the end search function (page 22) and start recording from that point. |
| | | Point "B" is too close to point "A". | Set point "B" again so that it is farther away from point "A". |
| Point "B" is before point "A". | | Set point "B" again so that it is located after point "A". | |

| | Symptom | Cause | Remedy |
|---|--|---|---|
| Sub code operation | End ID cannot be written during playback. | The portion where you want to write the end ID is blank. | Set the deck in the record-pause mode by pressing REC, then write the end ID. |
| | Renumbering function does not operate. | The portion between the end of a start ID and the beginning of the following start ID is less than 9 seconds (18 seconds in the long-play mode) long. | When writing the start IDs manually, write so that the intervals between them are more than 9 seconds (18 seconds in the long-play mode). |
| | Start ID cannot be erased. | | |
| | Skip ID cannot be erased. | Two skip IDs are written continuously. | When writing the skip IDs, write so that the intervals between them are more than 1 second (2 seconds in the long-play mode). |
| | End ID cannot be erased. | The end ID is written at the beginning of the tape. | Start recording from the beginning of the tape. |
| The end ID is written immediately after a start ID. | | First erase the start ID. | |
| Others | Tape transport noise seems excessively loud in rewind or fastforward mode. | This situation depends upon the cassette being used and is not a problem. | — |
| | The tape stops running suddenly. | A defective or damaged cassette has been inserted. | Press the OPEN/CLOSE button to change the tape. |
| | Unbalanced left and right volume. | Incorrect adjustment of the recording level. | Adjust the recording level correctly. (page 21) |
| | Increase of noise or deterioration of sound quality. | Contamination of the head. | Clean the head, using the cleaning tape. |
| | The clock for the date function does not operate once the power is off. | The battery built in this unit is weak. | Ask the Sony dealer to change the battery. |

Specifications

| | |
|------------------|--|
| Tape | Digital audio tape |
| Recording head | Rotary head |
| Recording time | Standard: 120 minutes. Long-play mode: 240 minutes (with DT-120) |
| Tape speed | Standard: 8.15 mm/s, Long play mode: 4.075 mm/s |
| Drum rotation | Standard: 2,000 rpm, Long-play mode: 1,000 rpm |
| Error correction | Double Read Solomon code |

Tape

| | |
|-------------------------------|---|
| Track pitch | 13.6 μ m (20.4 μ m) |
| Sampling frequency | 48 kHz, 44.1 kHz, 32 kHz |
| Modulation system | 8-10 Modulation |
| Transfer rate | 2.46 Mbit/sec. |
| Number of channel | 2 channels, stereo |
| D/A conversion (Quantization) | Standard: 16-bit linear Long-play mode: 12-bit non-linear |
| Frequency response | Standard: 2-22,000 Hz (\pm 0.5 dB) Long-play mode: 2-14,500 Hz (\pm 0.5 dB) |
| Signal to noise ratio | Standard: more than 94 dB Long-play mode: more than 93 dB |
| Dynamic range | Standard: more than 94 dB Long-play mode: more than 93 dB |
| Total harmonic distortion | Standard: less than 0.004% (1 kHz) Long-play mode: less than 0.08% (1 kHz) |
| Wow and flutter | Below measurable limit (\pm 0.001% W. PEAK) |

Input

| | Jack type | Impedance | Rated input level |
|-------------------|--------------|-----------|-------------------|
| LINE IN | phono jack | 47 kohms | -4 dBs |
| DIGITAL IN | phono jack | 75 ohms | 0.5 Vp-p, 20% |
| DIGITAL IN | optical jack | — | — |

Output

| | Jack type | Impedance | Rated output | Load impedance |
|-----------------|-------------------|-----------|--------------|--------------------|
| LINE OUT | phono jack | 470 ohms | -4 dBs | More than 10 kohms |
| PHONES | stereo phone jack | 220 ohms | 2.0 mW | 32 ohms |

DIGITAL OUT (optical jack): wavelength 660 nm

General

| | |
|--------------------|--|
| Power requirements | 120 V AC, 60 Hz |
| Power consumption | 37 W |
| Dimensions | Approx. 470x135x350 mm (w/h/d) (18 ⁵ / ₈ x 5 ³ / ₈ x 13 ⁷ / ₈ inches) |
| Weight | Approx. 11 kg (24 lb 50 oz) |

Remote commander (supplied)

| | |
|-----------------------|--|
| Remote control system | Infrared control |
| Power requirements | 3V DC, with two size AA (R6) batteries |
| Dimensions | Approx. 63x19x175 mm (w/h/d) (2 ¹ / ₂ x ³ / ₄ x 7 inches) |
| Weight | Approx. 130 g (4 oz) incl. batteries. |

Supplied accessories

Sony batteries SUM-3(NS) (2)
Audio connecting cords (2 phono plugs - 2 phono plugs, stereo for line inputs and outputs) (2)
Screws (4)

Design and specifications subject to change without notice.

Accessories not supplied

| | |
|-------------------|--|
| Optical cable | POC-15, etc. |
| Connecting cord | RK-C77 (2 phono plugs - 2 phono plugs:connectors plated with gold, high quality litz line cord) VMC-1ES, 3ES, etc. (phono plug - phono plug): for digital connection |
| Cleaning cassette | DT-10CL |